



ASW5120-LB-G3

User Manual



Android



iOS

Contents

1	General information	3
1.1	About this document.....	3
1.2	Product validity.....	3
1.3	Target group.....	3
1.4	Symbols	4
2	Safety.....	5
2.1	Intended use	5
2.2	Important safety instructions.....	5
2.3	Symbols on the label.....	7
3	Unpacking and storage.....	8
3.1	Scope of delivery	8
3.2	Product storage	10
4	Battery system overview	12
4.1	Product description.....	12
4.2	Dimensions.....	13
4.3	LED indicator	13
4.4	Remote operation	18
4.5	Interfaces and functions	18
4.6	Fire Fighting Systemss.....	19
5	Mounting	20
5.1	Requirements for mounting.....	20
5.2	Mounting.....	23
6	Electrical connection.....	31
6.1	Overview of the connection area.....	31
6.2	Connecting the grounding conductor.....	31
6.3	Connecting the power cable and network cable.....	33
6.4	System wiring Diagram	42
7	Commissioning and operating	45
7.1	Inspection before commissioning	45
7.2	Commissioning procedure.....	45
8	Decommissioning the product	46
9	Technical data	47
10	Troubleshooting	48
11	Maintenance.....	48
12	Recycling and disposal	49
13	EU declaration of conformity	49
14	Service and warranty.....	49
15	Contact.....	50

1 General information

1.1 About this document

This document describes the mounting, installation, commissioning, configuration, operation, troubleshooting and decommissioning of the Ai-LB battery energy storage system (BESS).

You will find the latest version of this document and further information on the BESS in PDF format at www.solplanet.net.

It is recommended that this document be readily accessible at all times.

1.2 Product validity

This document is valid for the following models:

- ASW5120-LB-G3

1.3 Target group

This document is intended for qualified persons who must perform the tasks exactly as described in this user manual.

All installation work must be performed by appropriately trained and qualified persons.

Qualified persons must possess the following skills:

- Knowledge of how batteries work and are operated.
- Knowledge of how an inverter works and is operated.
- Training in how to deal with the dangers and risks associated with installing, repairing and using electrical devices and batteries and installations.
- Training in the installation and commissioning of electrical devices.
- Knowledge of all applicable laws, standards and directives.
- Knowledge of and compliance with this document and all safety information.

Not adhering to the prescribed instructions may potentially void the manufacturer's warranty. If in doubt please contact the local Solplanet service team.

1.4 Symbols

DANGER

Indicates a hazardous situation which, if not avoided, will result in death or serious injury.

WARNING

Indicates a hazardous situation which, if not avoided, could result in death or serious injury.

CAUTION

Indicates a hazardous situation which, if not avoided, could result in minor or moderate injury.

NOTICE

Indicates a situation which, if not avoided, can result in property damage.



Information that is important for a specific topic or goal, however not related to safety.

2 Safety

2.1 Intended use

The ASW5120-LB-G3 is a BESS which is for both residential and commercial applications and operates with Solplanet hybrid inverters.

- It is a low voltage Li-ion BESS controlled via a battery control unit.
- It can be operated in on-grid, off-grid and backup modes with all officially compatible Solplanet inverters.
- The product is suitable for indoor and outdoor use.
- The product must only be used as stationary equipment.
- Alterations to the product are not allowed unless authorised in writing by Solplanet.
- Unauthorised alterations will void the guarantee and warranty claims. Solplanet will not be held liable for any damage caused by such unauthorised alterations.
- The product is not suitable for supplying power to life-sustaining medical devices.
- Please ensure that no personal injury would lead due to the power outage of the battery system.
- The product must only be used in countries for which it is approved for by Solplanet.
- Use this product only in accordance with the information provided in this documentation and with the locally applicable standards and directives. Any other application may cause personal injury or property damage.
- The type label must remain permanently attached to the product.
- This document does not replace any regional, state, provincial, federal or national laws, regulations or standards that apply to the installation, electrical safety and use of the product.

2.2 Important safety instructions

The product has been designed and tested in accordance with international safety requirements.

To prevent personal injury and property damage and to ensure long-term operation of the product, read this section carefully and observe all safety information at all times.



Danger to life due to DC voltages of the battery!

When the battery system connected to the inverter, and the ON/OFF button switch is ON, the batteries will generate a DC voltage which will be present in the DC cable and live components.

- Do not touch non-insulated parts or cables.
- Do not touch the DC conductors.
- Do not touch any live components of the product.
- Do not open the product.
- All work on the product must only be carried out by qualified personnel who have read and fully understood all safety information contained in this document.
- Disconnect the product from voltage sources and ensure it cannot be reconnected before working on the product.
- Wear suitable personal protective equipment, in accordance with local regulations, when working on the product.

DANGER

Danger to life due to electric shock where surge protection is not used !

If there is no surge protection, a voltage surge can be conducted into the building and to other connected devices in the same system through power cables, network cables or other types of cable. Touching live parts and cables may result in death or lethal injury due to electric shock.

- Ensure all devices in the same system and the inverter are integrated within an existing surge protection systems/devices.
- Refer to local installation regulations to determine the requirements for the installation of surge protection devices.

WARNING

Danger to life due to electric shock from destruction of measurement devices due to overvoltage !

Overvoltage can damage a measurement device and result in voltage being present in the enclosure of the measurement device. Touching the live enclosure of the measuring device results in death or lethal injuries due to electric shock.

- Only use measuring devices with a higher voltage range than the battery system' voltage.

WARNING

Risk of injury due to weight of product !

Injuries may result if the product is lifted incorrectly or dropped while being transported or mounted.

- Lift and transport the product carefully.
- Wear suitable personal protective equipment, in accordance with local regulations, when working on the product.

NOTICE

Damage to the battery system due to electrostatic discharge!

Internal components of the battery system can be irreparably damaged by electrostatic discharge.

- Ground yourself before touching any component.

NOTICE

Damage to the battery due to particles and water!

Particles such as dust and sand can damage the battery and impair its functionality.

- Only open the battery cover when the humidity is within the permitted range of the product and the environment is free of dust and sand.

2.3 Symbols on the label



Beware of a danger zone
This symbol indicates that the product must be additionally grounded if additional grounding or equipotential bonding is required at the installation site.



Beware of DC voltage and operating current!
The product operates at a DC voltage and current. Work on the product must only be carried out by skilled and authorized personnel.



Beware of explosion!
The battery is an electro-chemical device, and there is an explosion risk in extreme cases. Please keep away of it when the danger occurs.



Beware of danger to children!
The battery must be inaccessible to children.



Flammable
Keep the battery system away from open flames or ignition sources.



WEEE Designation
Do not dispose of the product together with household waste. Dispose the product in accordance with local disposal regulations for electronic waste.



CE marking
The product complies with the requirements of the applicable EU directives.



Certification mark
The product has been tested by TÜV and obtained the quality certification mark.



RCM Mark
The product complies with the requirements of the applicable Australian standards.



The battery is recyclable
The battery can be recycled by a professional recycling organization, please refer to the relevant local regulations.



Observe the documentation
Read and understand all documentation supplied with the product.

3 Unpacking and storage

3.1 Scope of delivery

Check the scope of delivery for completeness and any visible external damage. Contact your distributor if the scope of delivery is incomplete or damaged.

3.1.1 Standard package

Battery Module Package:

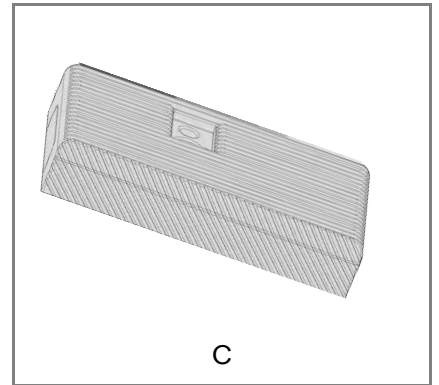
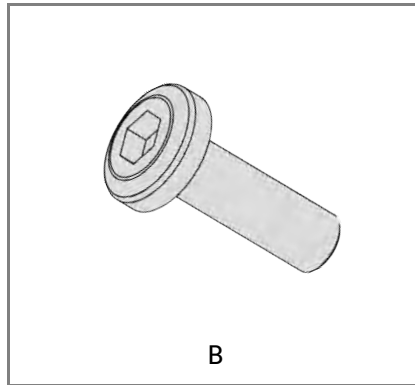
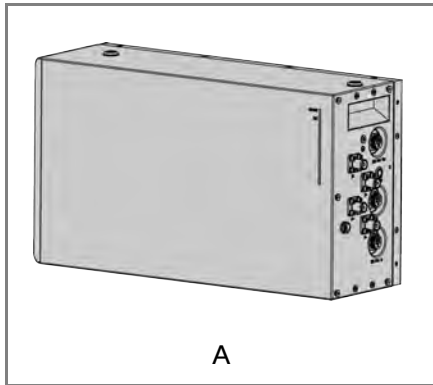

Base Package:

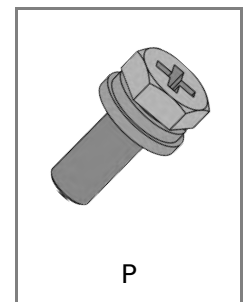
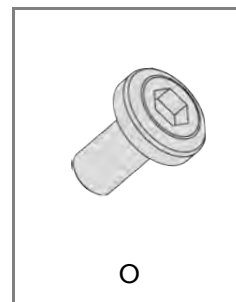
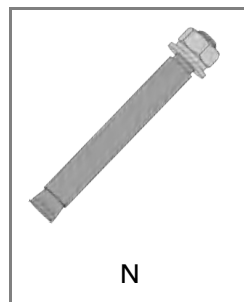
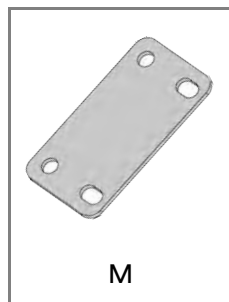
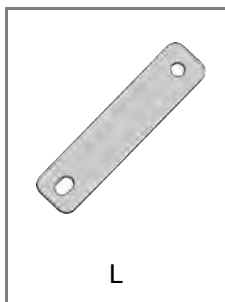
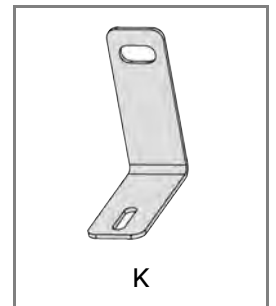
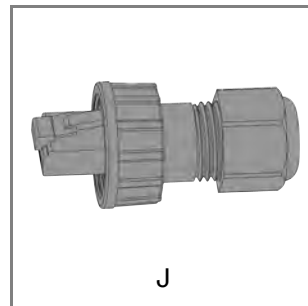
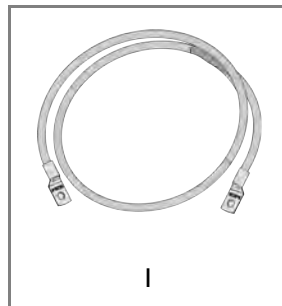
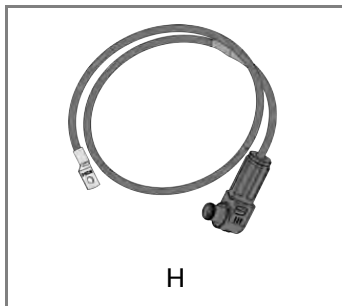
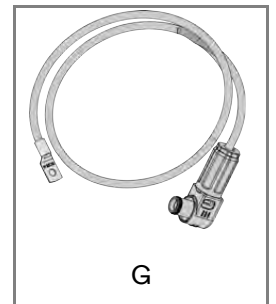
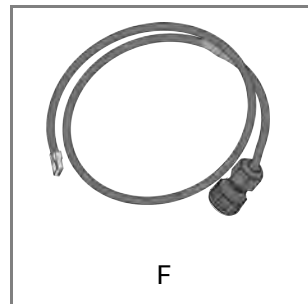
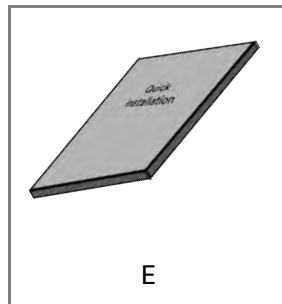
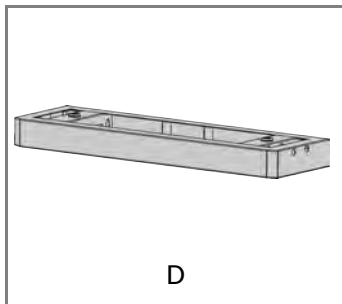

Object	Description	Quantity
A	Battery module	1
B	M5x16 Screw	1
C	Decorative cover	1
D	Base	1
E	Quick installation guide	1
F	Communication output cable (2m)	1
G	Positive cable (2m)	1
H	Negative cable (2m)	1
I	PE cable (2m)	1
J	Terminating resistor	1
K	L-bracket	2
L	Module locking plate (left)	1
M	Module locking plate (right)	1
N	Expansion Anchor Bolt (M8 X 80)	2
O	M5X10 Screw	8
P	Hexagon Screw (M6 X 16)	1

3.2.2 Optional package

Parallel Connection Package (only in parallel version)

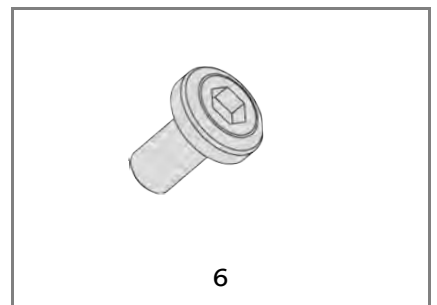
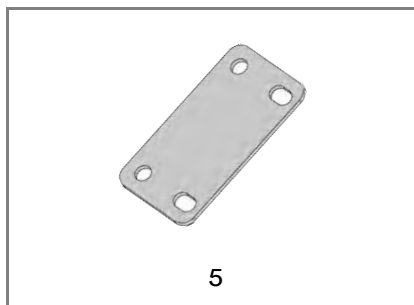
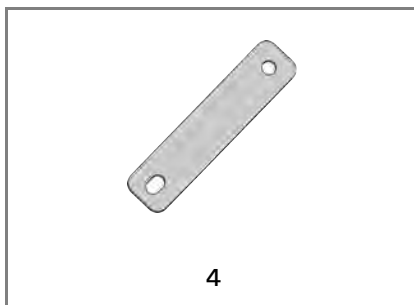
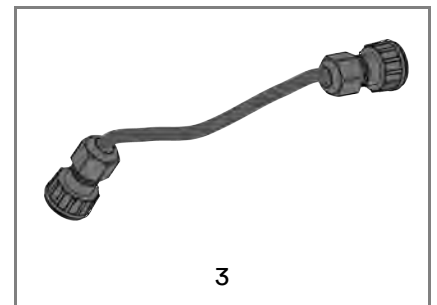
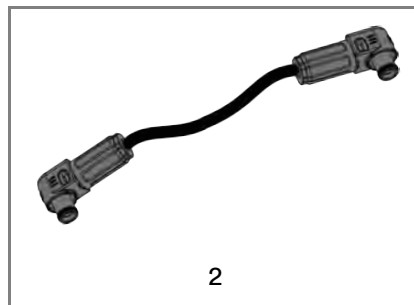
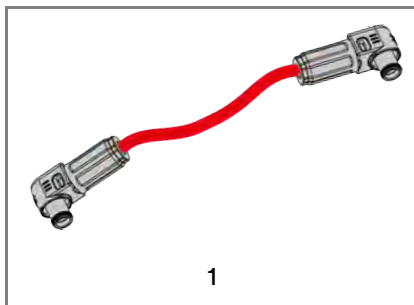

Output Cable(3m) Package

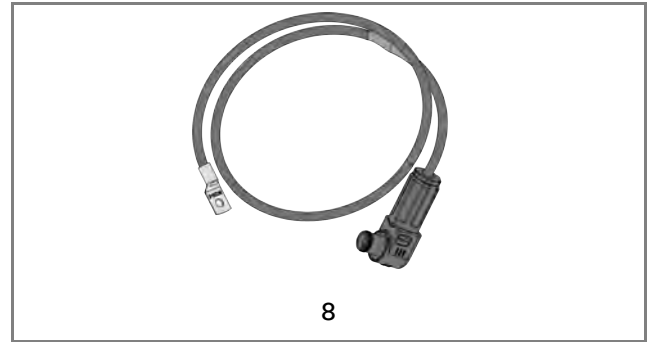
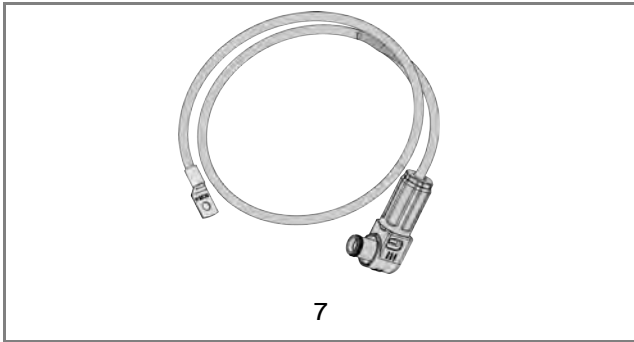

Wall mounting Optional Package

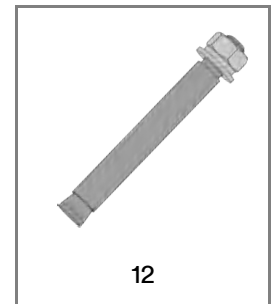
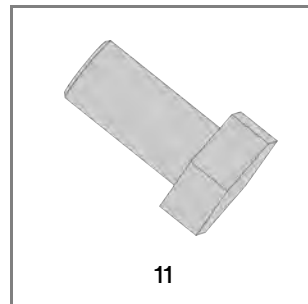
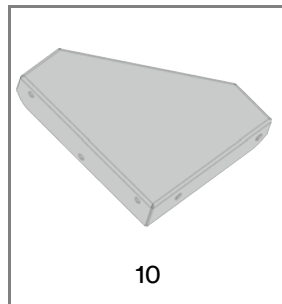

Object	Description	Quantity
1	Parallel Positive Cable	1
2	Parallel Negative Cable	1
3	Parallel Communication Cable	1
4	Module locking plate (left)	1
5	Module locking plate (right)	1
6	M5X10 Screw	6
7	Positive Cable-Optional (3m)	1
8	Negative Cable-Optional (3m)	1
9	Wall bracket(left)	1
10	Wall bracket(right)	1
11	M10*20 Bolt	4
12	Expansion Anchor Bolt (M8 X 80)	6

3.2 Product storage

Suitable storage is required if the equipment is not installed immediately:

- Store the battery in the original packing case.
- The storage temperature must be between -20°C to +45°C, and the storage relative humidity must be between 5% and 95%, non-condensing.

- The storage SOC: 25%~50%. Re-charge the battery every 6 months, to ensure no over-discharge of the battery occurs.
- The packing with the equipment shall not be tilted or inverted.
- Place the equipment in a cool place away from direct sunlight.
- Keep the equipment away from flammable, explosive, and corrosive materials.
- Keep the equipment away from rain.
- The product must be fully inspected and tested by authorised personnel before it can be put into operation, if it has been stored for three or more months.

4 Battery system overview

4.1 Product description

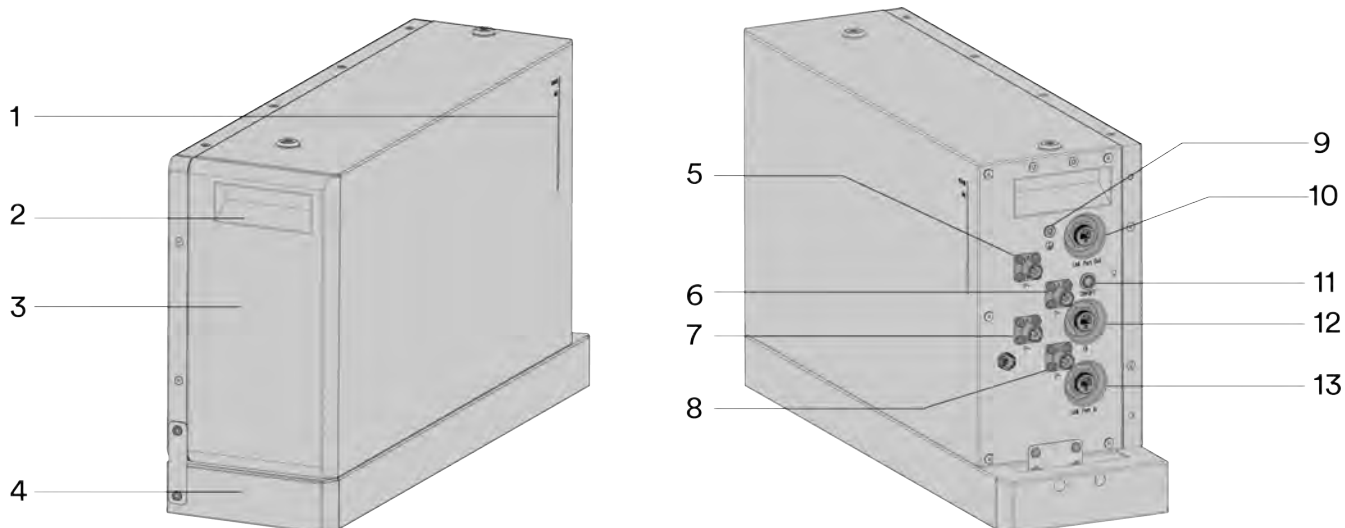

Figures shown here are for reference only. The actual product received may differ!

Object	Description
1	LED indicator
2	Handle
3	Battery module
4	Base
5	P+
6	P-
7	P+
8	P-
9	Grounding
10	Link port out
11	On/Off
12	DI
13	Link port in

4.2 Dimensions

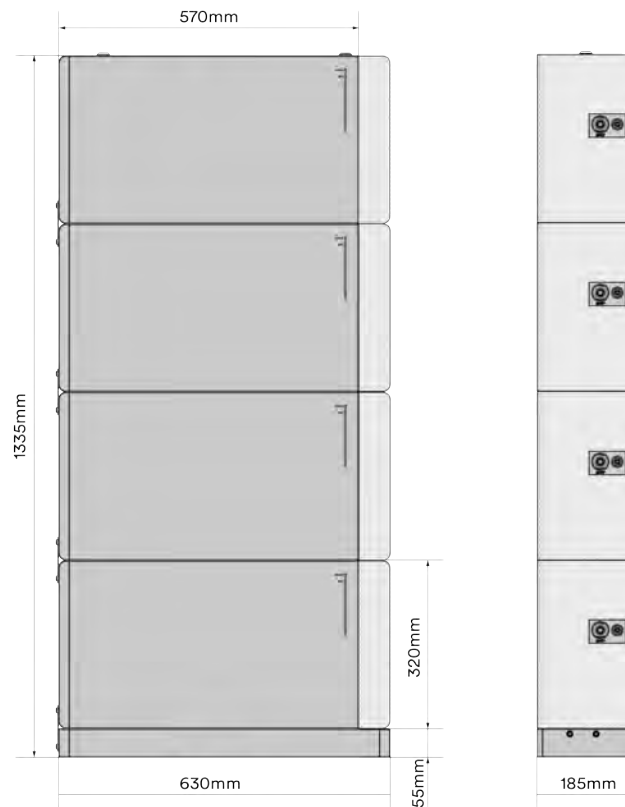

4.3 LED indicator

The LED's on the battery system indicates the status of the BESS.



LED status definitions:

- Solid On: LED is permanently illuminated.
- Off: LED is off (is not illuminated).
- Breathing: The LED is cyclic light on from dark to bright.

Function	LED	Description
Status	Solid ON	Indicates normal state.
	Breathing	Indicates sleep state.
	Blinking	Indicates communication loss.
	Solid ON	Indicates an alarm.
	Solid ON	Indicates a fault.
	Off	Indicates shutdown state.

SOC	<input checked="" type="radio"/> ON	SOC:90%~100%
	<input checked="" type="radio"/> ON	
	<input checked="" type="radio"/> ON	
	<input checked="" type="radio"/> ON	
	<input checked="" type="radio"/> ON	
	<input checked="" type="radio"/> ON	
	<input checked="" type="radio"/> ON	
	<input checked="" type="radio"/> ON	
	<input checked="" type="radio"/> ON	
	<input checked="" type="radio"/> ON	
SOC	<input type="radio"/> OFF	SOC:80%~90%
	<input checked="" type="radio"/> ON	
	<input checked="" type="radio"/> ON	
	<input checked="" type="radio"/> ON	
	<input checked="" type="radio"/> ON	
	<input checked="" type="radio"/> ON	
	<input checked="" type="radio"/> ON	
	<input checked="" type="radio"/> ON	
	<input checked="" type="radio"/> ON	
	<input checked="" type="radio"/> ON	
SOC	<input type="radio"/> OFF	SOC:70%~80%
	<input type="radio"/> OFF	
	<input checked="" type="radio"/> ON	
	<input checked="" type="radio"/> ON	
	<input checked="" type="radio"/> ON	
	<input checked="" type="radio"/> ON	
	<input checked="" type="radio"/> ON	
	<input checked="" type="radio"/> ON	
	<input checked="" type="radio"/> ON	
	<input checked="" type="radio"/> ON	

SOC	<input type="radio"/> OFF	SOC:60%~70%
	<input type="radio"/> OFF	
	<input type="radio"/> OFF	
	<input checked="" type="radio"/> ON	
	<input checked="" type="radio"/> ON	
	<input checked="" type="radio"/> ON	
	<input checked="" type="radio"/> ON	
	<input checked="" type="radio"/> ON	
	<input checked="" type="radio"/> ON	
	<input checked="" type="radio"/> ON	
SOC	<input type="radio"/> OFF	SOC:50%~60%
	<input type="radio"/> OFF	
	<input type="radio"/> OFF	
	<input type="radio"/> OFF	
	<input checked="" type="radio"/> ON	
	<input checked="" type="radio"/> ON	
	<input checked="" type="radio"/> ON	
	<input checked="" type="radio"/> ON	
	<input checked="" type="radio"/> ON	
	<input checked="" type="radio"/> ON	
SOC	<input type="radio"/> OFF	SOC:40%~50%
	<input type="radio"/> OFF	
	<input type="radio"/> OFF	
	<input type="radio"/> OFF	
	<input type="radio"/> OFF	
	<input checked="" type="radio"/> ON	
	<input checked="" type="radio"/> ON	
	<input checked="" type="radio"/> ON	
	<input checked="" type="radio"/> ON	
	<input checked="" type="radio"/> ON	

SOC	<input type="radio"/> OFF	SOC:30%~40%
	<input type="radio"/> OFF	
	<input type="radio"/> OFF	
	<input type="radio"/> OFF	
	<input type="radio"/> OFF	
	<input type="radio"/> OFF	
	<input checked="" type="radio"/> ON	
	<input checked="" type="radio"/> ON	
	<input checked="" type="radio"/> ON	
	<input checked="" type="radio"/> ON	
SOC	<input type="radio"/> OFF	SOC:20%~30%
	<input type="radio"/> OFF	
	<input type="radio"/> OFF	
	<input type="radio"/> OFF	
	<input type="radio"/> OFF	
	<input type="radio"/> OFF	
	<input type="radio"/> OFF	
	<input checked="" type="radio"/> ON	
	<input checked="" type="radio"/> ON	
	<input checked="" type="radio"/> ON	
SOC	<input type="radio"/> OFF	SOC:10%~20%
	<input type="radio"/> OFF	
	<input type="radio"/> OFF	
	<input type="radio"/> OFF	
	<input type="radio"/> OFF	
	<input type="radio"/> OFF	
	<input type="radio"/> OFF	
	<input type="radio"/> OFF	
	<input checked="" type="radio"/> ON	
	<input checked="" type="radio"/> ON	

SOC	● OFF	SOC:0%~10%
	● OFF	
	● OFF	
	● OFF	
	● OFF	
	● OFF	
	● OFF	
	● OFF	
	● OFF	
	● OFF	
	● ON	
SOC	● ON	Firmware update state
	● ON	
	● ON	
	● ON	
	● ON	
	● ON	
	● ON	
	● ON	
	● ON	
	● ON	



There are ten LEDs to indicate the State of Charge (SOC) of the battery and the different status of the LEDs indicates the different working state of the battery.

- Discharging state: Solid on (all bright LEDs according to SOC).
- Charging state: the current SOC LED (N-1) is solid on, and the other SOC LED (11-N) light up every 0.5S from bottom to top sequentially and cycling.
- Idle state: the SOC indicator LED is solid on. When the SOC is lower than 4%, the SOC indicator LED turns orange.
- Sleep state: all the SOC and status indicator LED breath synchronously.
- Firmware update state: the SOC indicator LED is solid on with blue color.

4.4 Remote operation

The ASW5120-LB-G3 battery support remote control fuction in the Solplanet APP.

With the remote control function, you can achieve the fuction with battery Power on / Shutdown, Sleep / Wake up, Select LED color, Change LED brightness.

You can find the function in the more setting of the battery setting page.

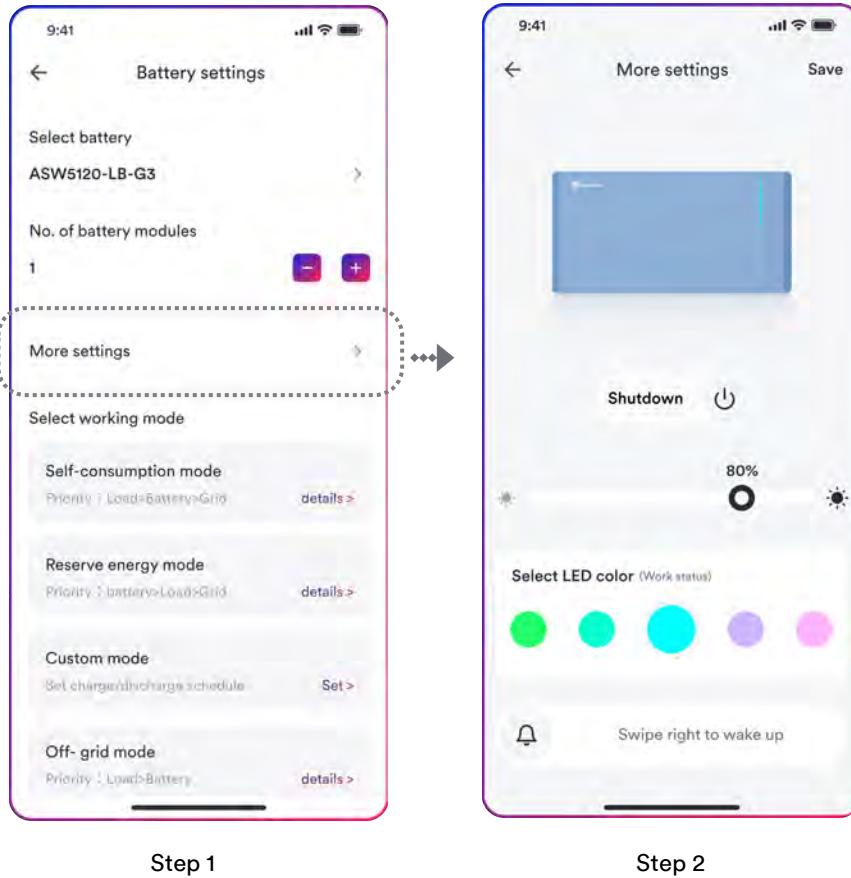

4.5 Interfaces and functions

The product is equipped with the following interfaces and functions:

System startup

Press the ON/OFF button for 1s, and then release the button, and wait LED light up, and the BESS is in working mode, and the device can be charged and discharged normally.

System shut down

Press the ON/OFF button for at least 5s. Make sure that both the SOC indicator and the status indicator LED of the battery system are off.



The parallel system has one key power on/off function. When one battery starts up or shuts down by the ON/OFF button, all the other parallel batteries will start up or shut down at the same time.

Communication (CAN) Interface - "Link Port"

The "Link Port" is an RJ45 port used for connecting the battery system to an inverter. The product can communicate with the inverter through the CAN interfaces. The CAN interfaces can also be used for the parallel operation of the products.

Digital input interface-"DI"

The "DI" is an RJ45 port used for connecting another battery cluster system. The product can communicate with the other battery cluster system. Detail system wiring connection can refer the figures in chapter 6.4.

4.6 Fire Fighting Systemss

The ASW5120-LB-G3 battery has a built-in intelligent aerosol extinguish device in each battery pack can quickly avoid the emergency safety risks.

According to the size of the battery module and cell capacity, the aerosol installed in the battery module can effectively extinguish the first fire of the cell, and the battery module fire from the inside to out is the most effective fire extinguishing method, which can minimize the thermal runaway loss.

The aerosol extinguish device that build-in is QRR0.03G/S, with a dose of 30g, using a length of 500mm double-output thermal wire and a length of 40mm glass fiber tube protection in the aerosol outlet. When the temperature of the battery module is detected by the thermal line $\geq 185^{\circ}\text{C}$, the thermal line burns and activates the aerosol generator in the fire extinguishing device, the aerosol will automatically start spraying the agent, and the spraying time is $\leq 12\text{s}$. It can extinguish the fire safety issue and prevent it's second recurrence effectively.

5 Mounting

5.1 Requirements for mounting

5.1.1 Requirements for Installation Location

DANGER

Danger to life due to fire or explosion!





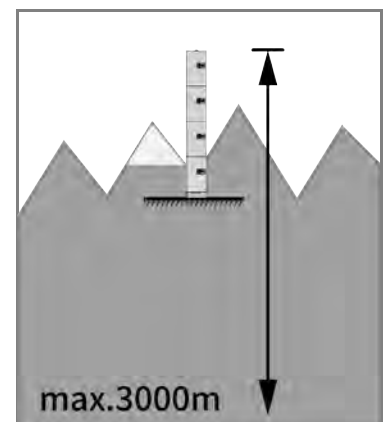
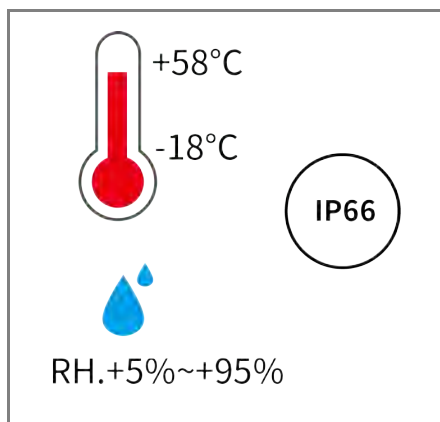

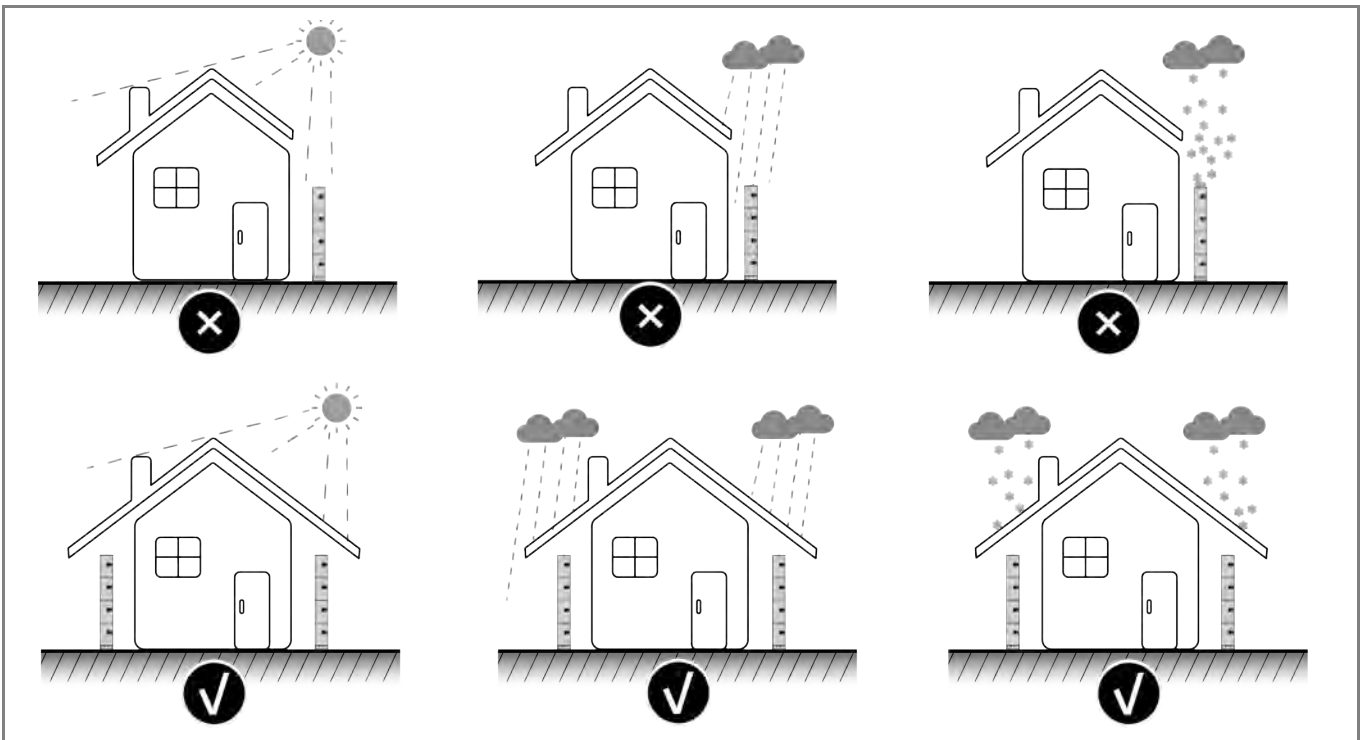
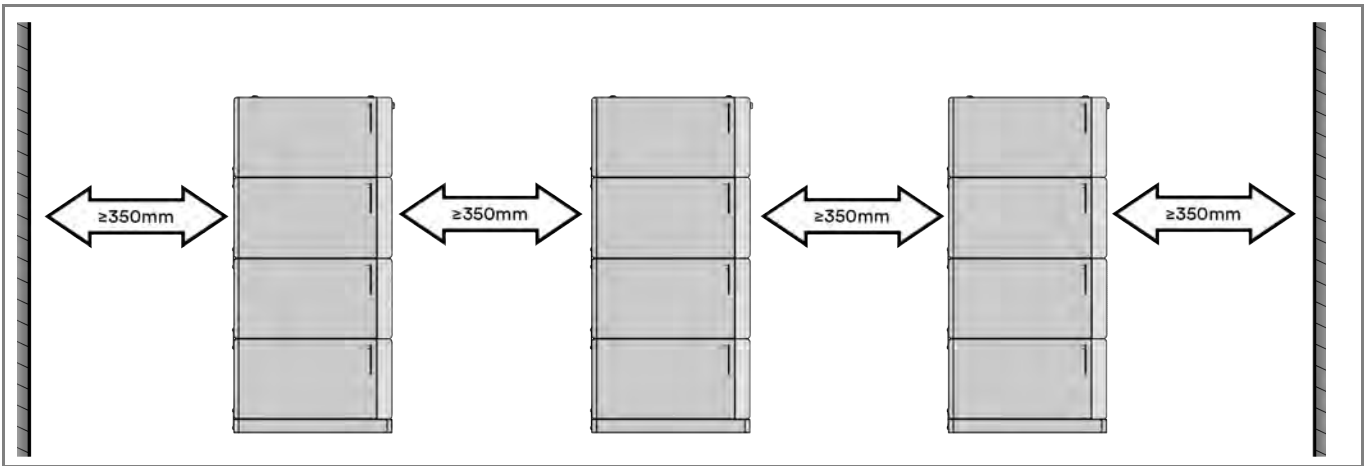
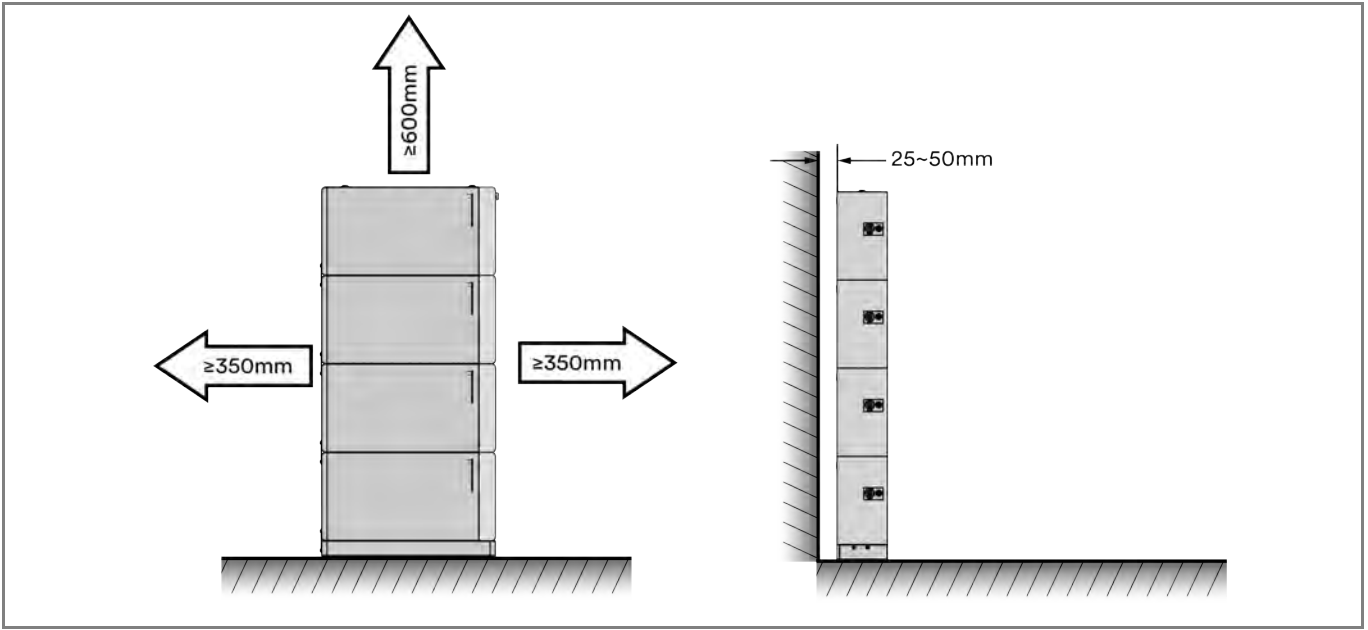



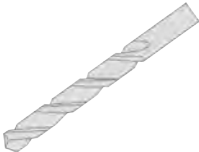

Despite careful construction, electrical devices can cause fires. This can result in death or serious injury.

- Do not mount the product in areas containing highly flammable materials or gases.
- Do not mount the inverter in areas where there is a risk of explosion.
- A solid support surface must be available (e.g. concrete or masonry).
- The mounting location must be inaccessible to children.
- The installation location must be suitable for the weight and dimensions of the BESS.
- Keep away from conductive (metal) dust.
- Keep away from water sources, heat sources and inflammable and explosive articles.
- The installation location must not be close to fire.
- The product should be mounted such that the LED indicators can be read without difficulty.
- The circuit breaker of the BESS must always be freely accessible.
- The altitude of the installation location should be less than 3000 m.
- The operating temperature should be between -18°C ~ $+58^{\circ}\text{C}$.
- The ambient humidity should be between 5~95%.
- The mounting location must not be exposed to direct solar irradiation. If the product is exposed to direct solar irradiation, the exterior components may age prematurely and overheating might occur. When becoming too hot, the BESS reduces its power output to avoid overheating, and will reduce its lifetime also.



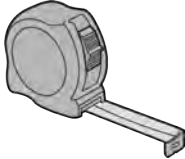
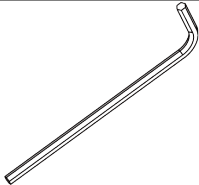

5.1.2 Tools

 <p>Phillips-screwdriver Specification: M5/M6</p>	 <p>Marker pen</p>	 <p>Phillips Screwdriver Bit Specification: M5 / M6</p>	 <p>Wrench</p>
 <p>Torque wrench</p>	 <p>Twist drill(10mm)</p>	 <p>Hexagon socket bit S=4</p>	 <p>Heat Gun</p>
 <p>Electric Drill</p>	 <p>Network Cable Crimping Tool</p>	 <p>Wire Stripper</p>	 <p>Crimping Pliers</p>
 <p>Scissor</p>	 <p>Hammer</p>	 <p>Tape measure</p>	 <p>Hex Key S=4</p>

5.1.3 Safety gear

Wear the following safety gear when working on the BESS. Adhere to local occupational health and safety standards.

 <p>Insulated gloves</p>	 <p>Safety goggles</p>	 <p>Safety shoes</p>
---	---	---

5.2 Mounting

DANGER

Danger to life due to DC voltages of the battery!

When the battery system connected to the inverter, and the ON/OFF button switch is ON, the batteries will generate a DC voltage which will be present in the DC cable and live components.

- Do not touch non-insulated parts or cables.
- Do not touch the DC conductors.
- Do not touch any live components of the product.
- Do not open the product.
- All work on the product must only be carried out by qualified personnel who have read and fully understood all safety information contained in this document.
- Disconnect the product from voltage sources and ensure it cannot be reconnected before working on the product.
- Wear suitable personal protective equipment, in accordance with local regulations, when working on the product.

WARNING

Risk of injury due to weight of product!

Injuries may result if the product is lifted incorrectly or dropped while being transported or mounted.

- Lift and transport the product carefully.
- Wear suitable personal protective equipment, in accordance with local regulations, when working on the product.

Step 1: Open the packaging box and take out the base and battery module in sequence.

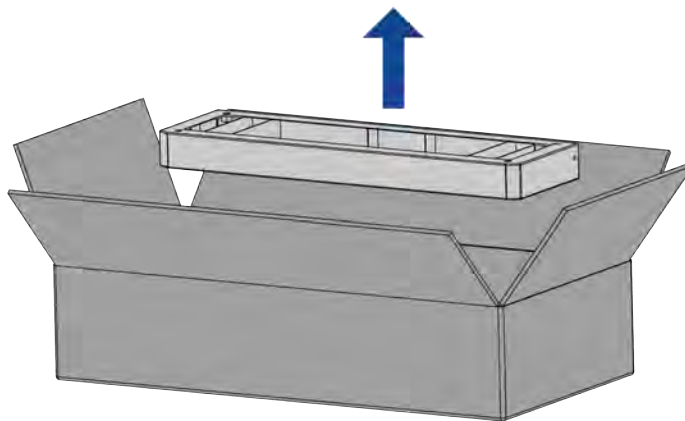

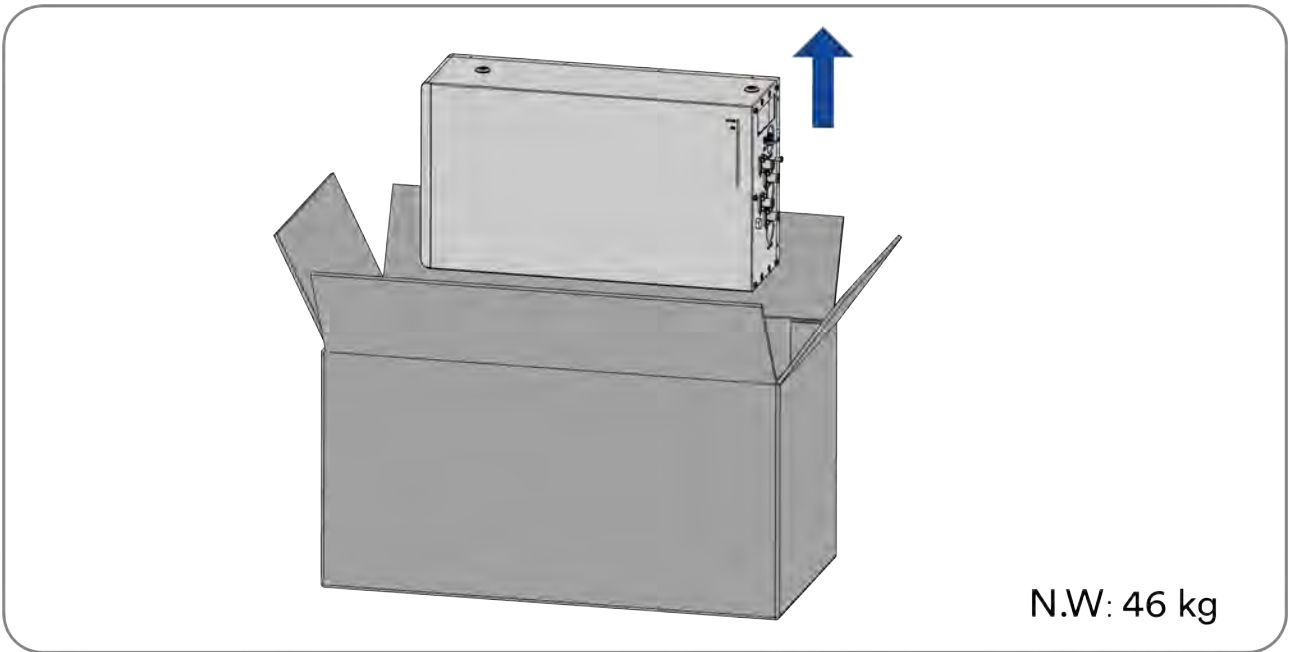

Step 2: Stack one battery module on the base.

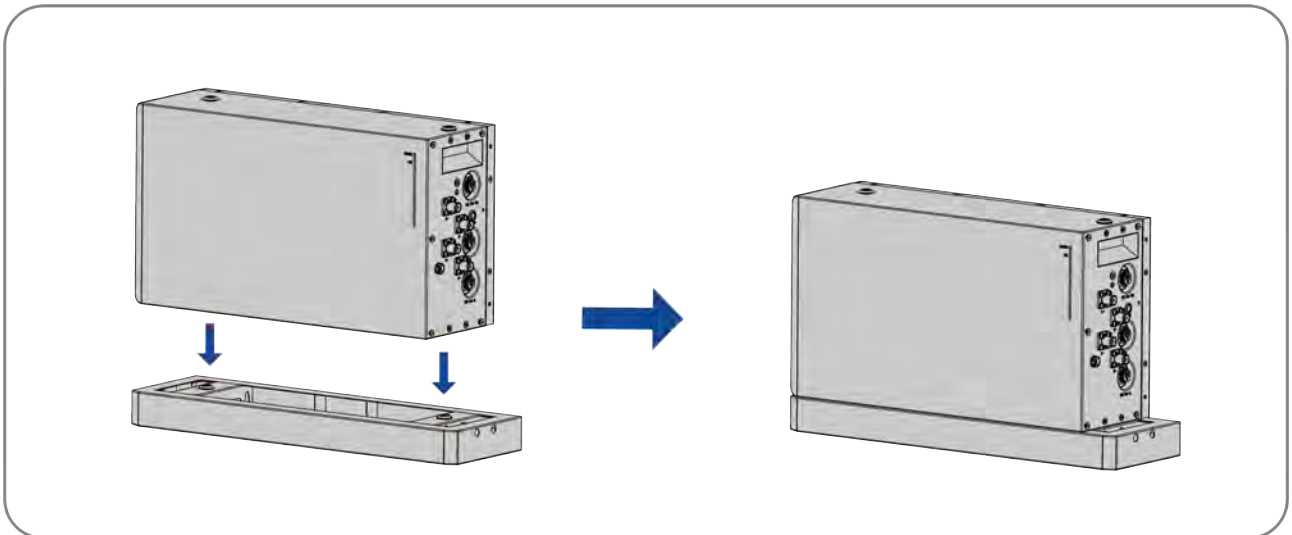

Step 3: Install the right anti-tipping bracket, using the module locking plate (right) to align the screw holes from above. Use four screws (M5x10) to secure the module lock plate (right), tightening torque :4 N.m.

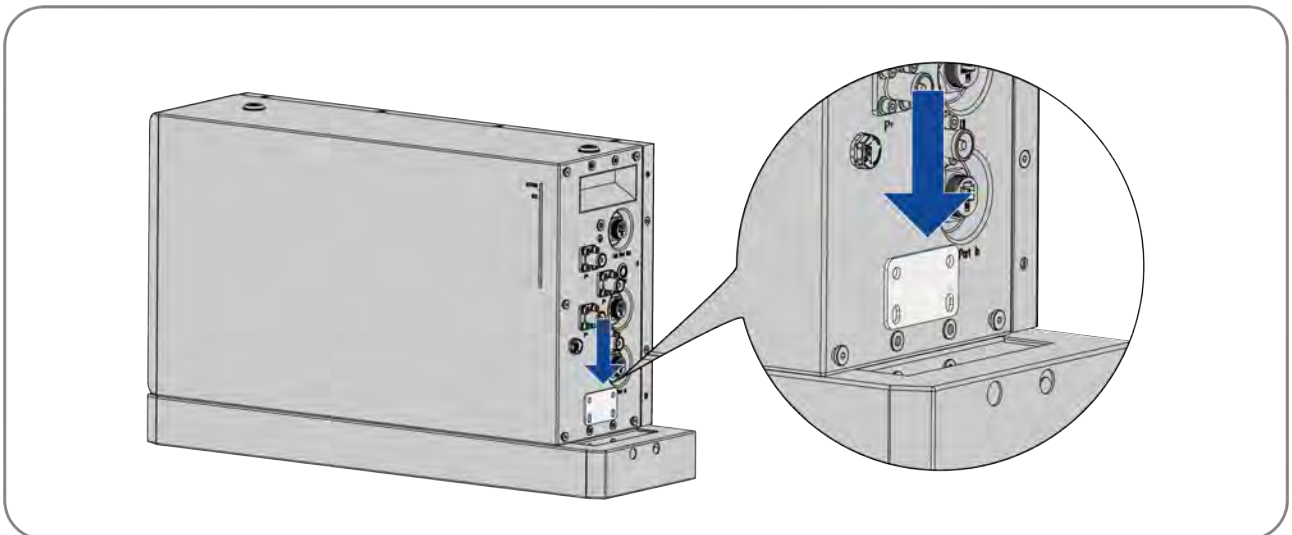

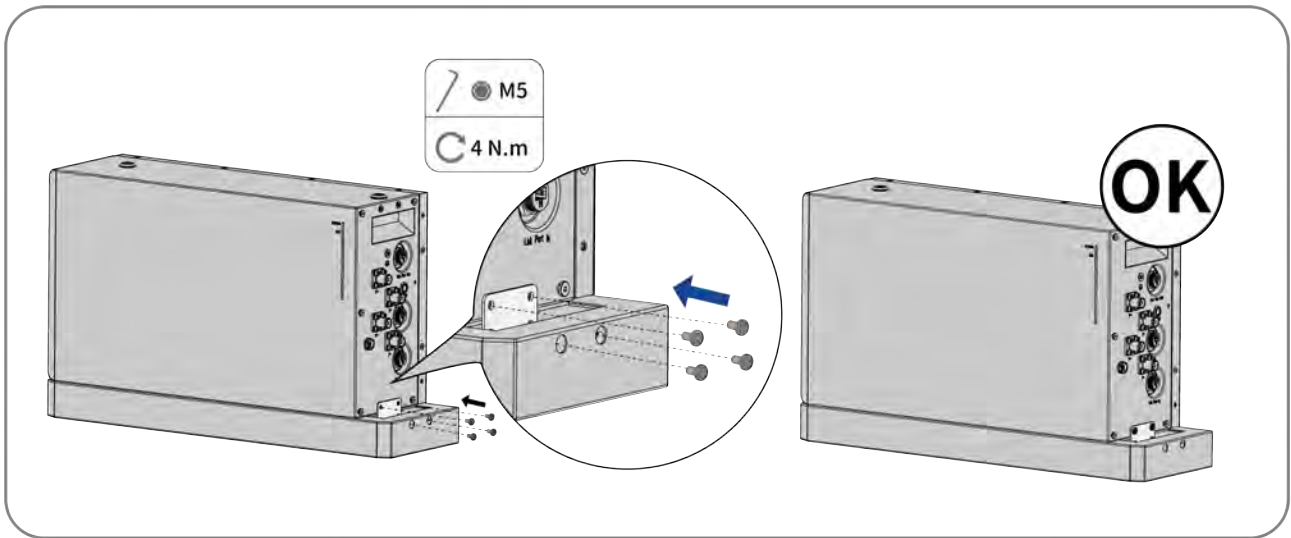

Step 4: Install the left anti-tipping bracket, using the module locking plate (left) to align the screw holes from above. Use four screws (M5x10) to secure the module lock plate (right), tightening torque :4 N.m.

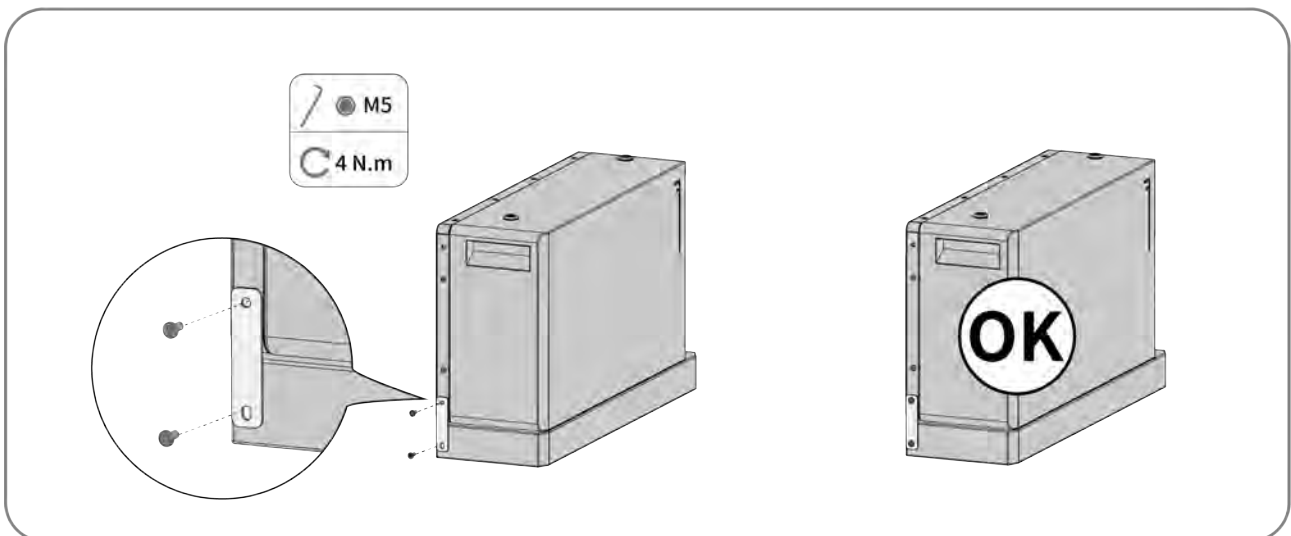
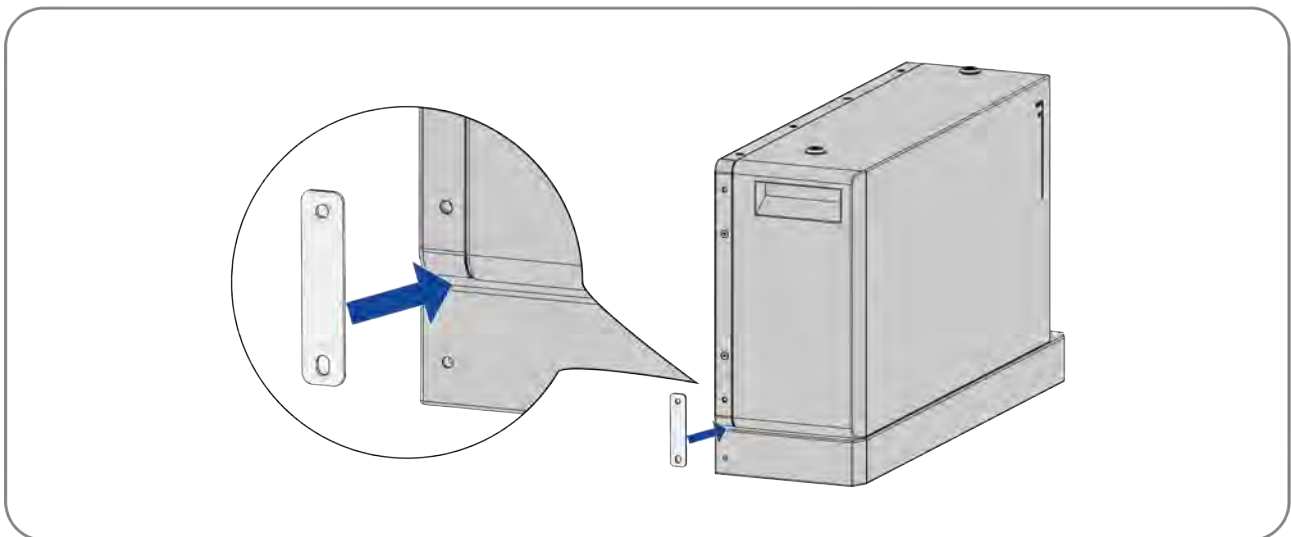

Step 5: Repeat the operations for the remaining battery modules.

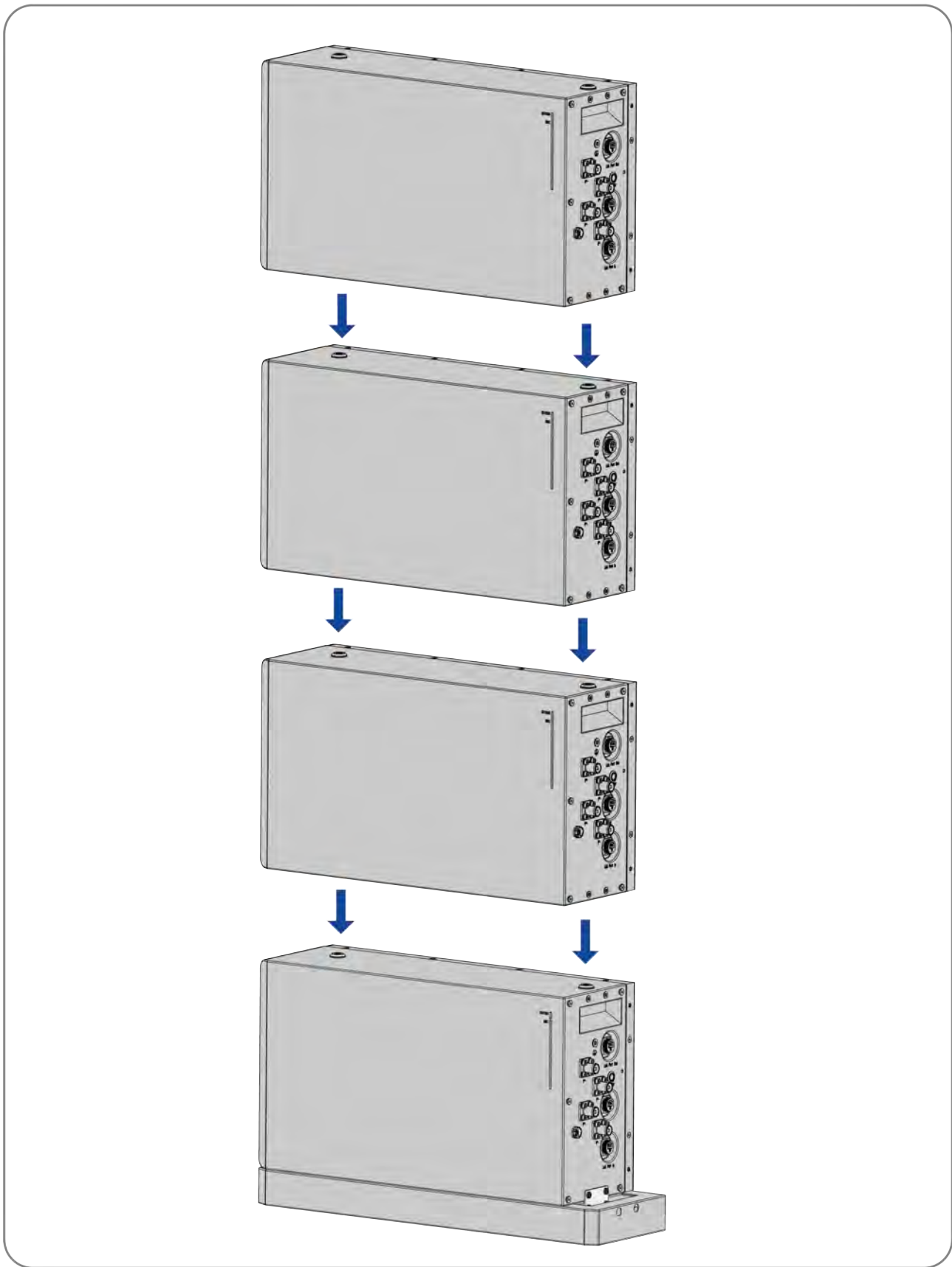

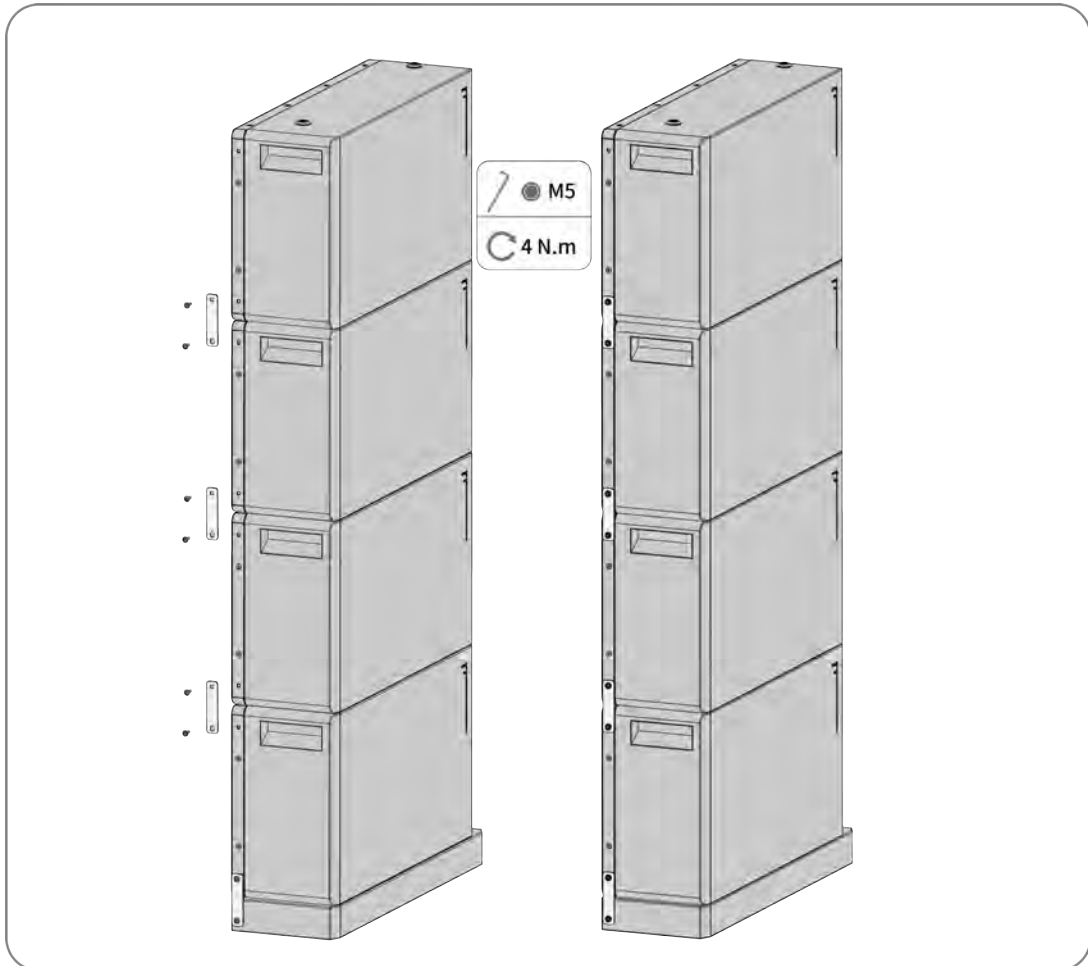
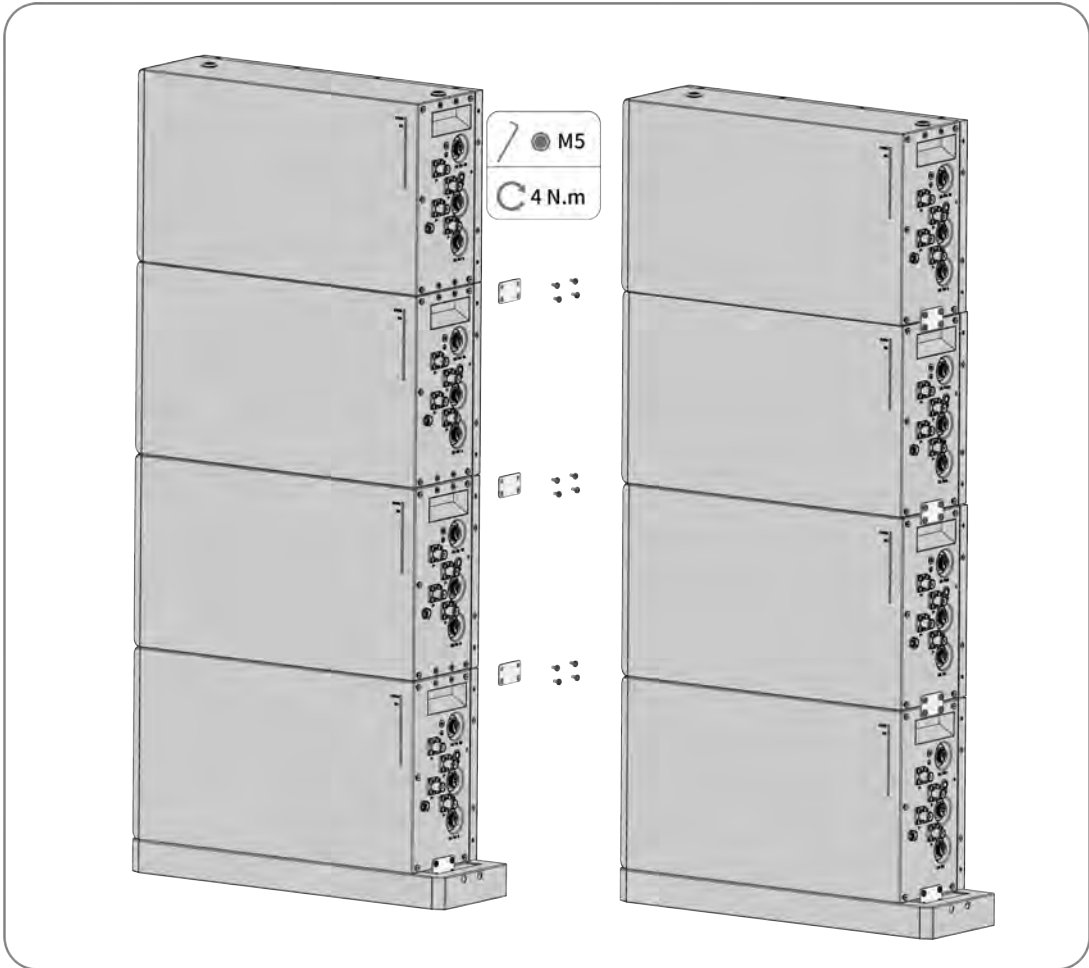

Step 6: Hold the L-bracket where it intends to be mounted on the wall and mark the position of the holes. Please pay attention that there may be power cables or other supply lines (e.g., gas or water) routed in the wall. Ensure that no cables or other supply lines are laid in the wall, which could be damaged when drilling holes. Repeat on the other side of the battery.

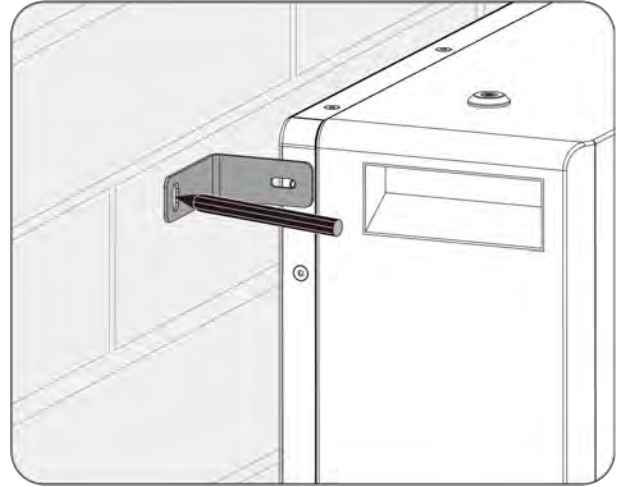
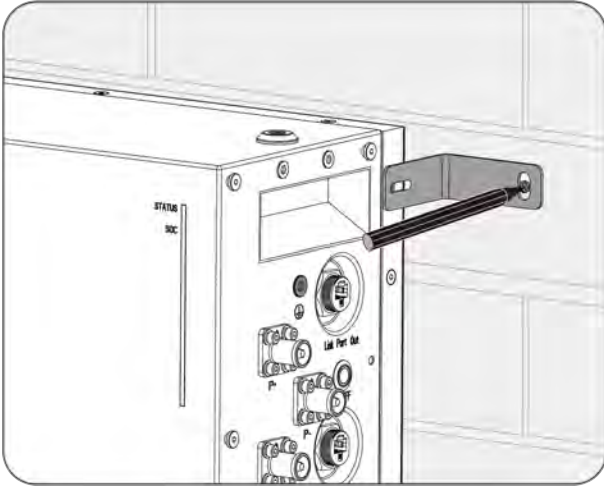

CAUTION

Damage to power cables and pipes can cause personal injury!

The walls may contain electrical cable or pipes (for example, gas or water).

- Ensure that power cable or pipes are not damaged when drilling.

Step 7: Set the L-bracket aside and drill the marked holes, at a diameter of 10 mm and a depth of 70 mm. Keep the hammer drill bit perpendicular to the wall to avoid drilling inclined. Repeat on the other side of the battery.

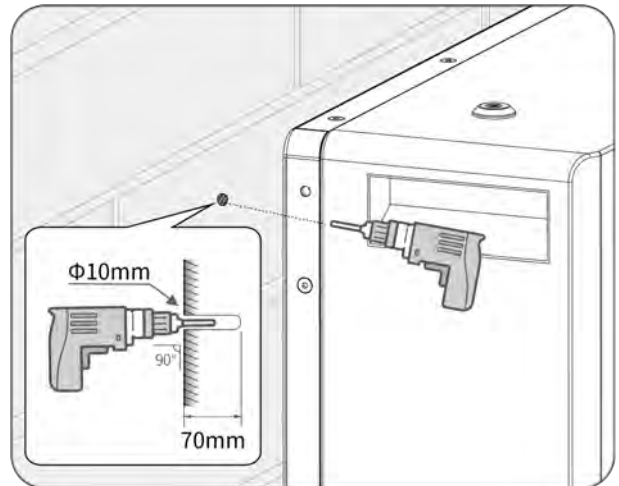
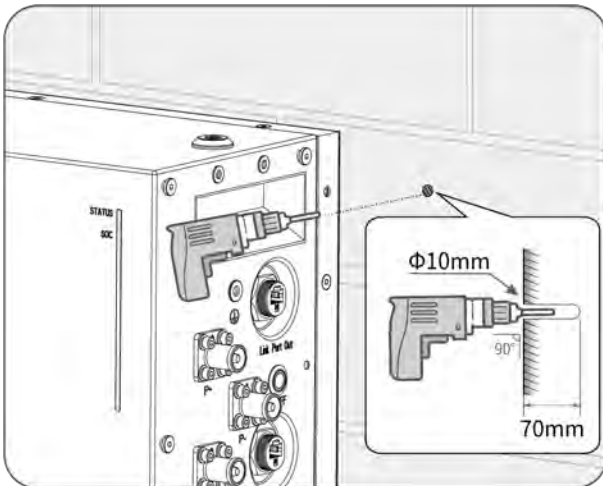

Step 8: Clean the dust in the hole, plug the expansion bolt into the hole, fix them with a rubber hammer, and tighten the nuts with a wrench, fix the bolt tail, and remove the nut, spring washer and flat washer and reserve them for the next step. Repeat on the other side of the battery.

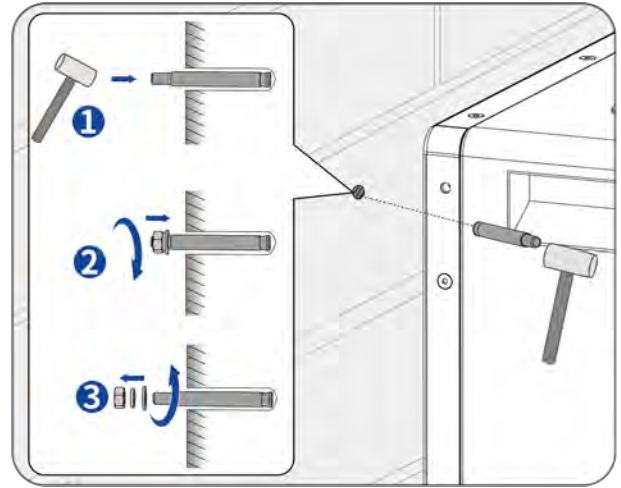
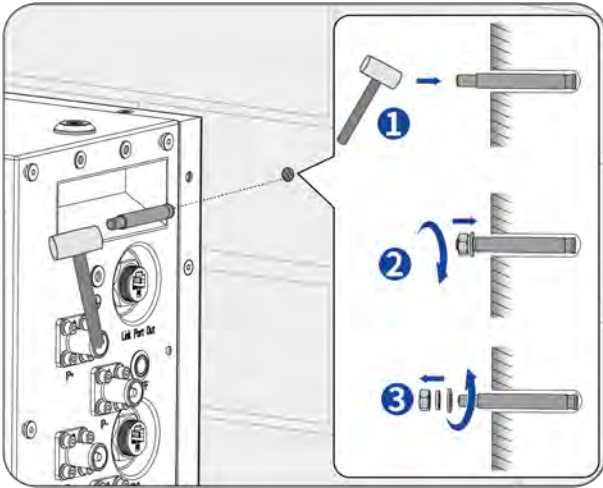

Step 9: Fix two L-brackets on both sides of the battery with the supplied screws(M5×10), using a Ratchet wrench (4mm) to tighten it (torque: 4 N.m).

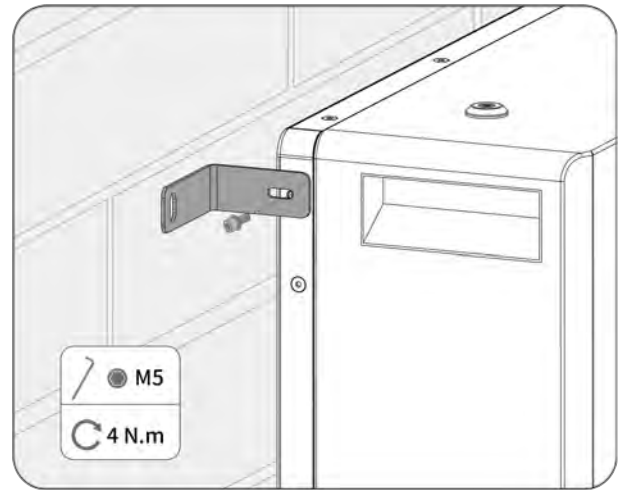
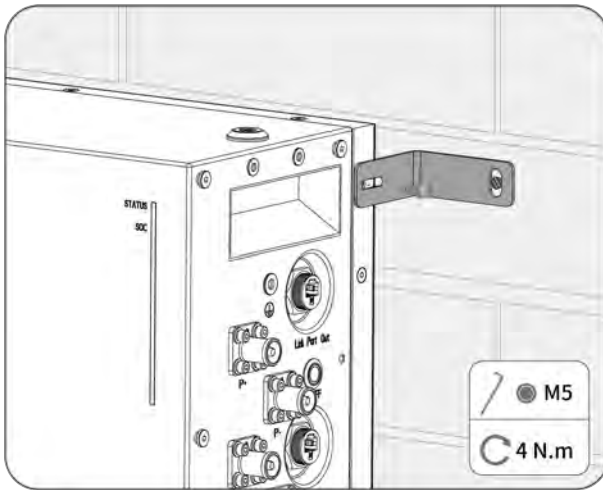

Step 10: Fix the L-brackets with the expansion bolts.

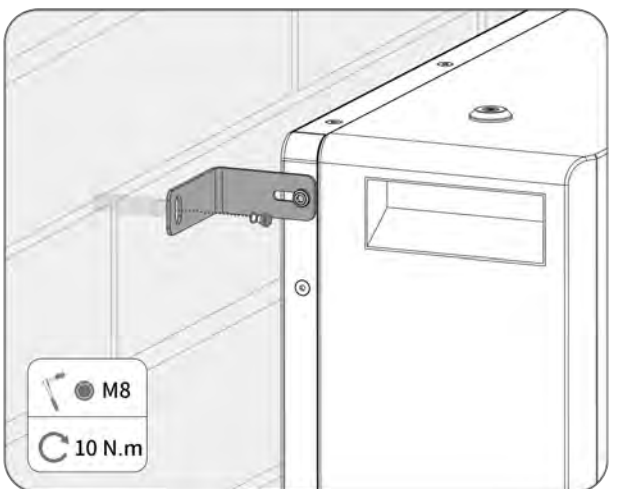
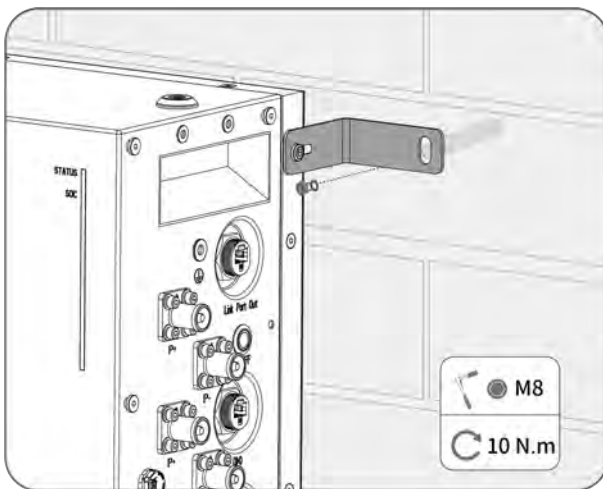

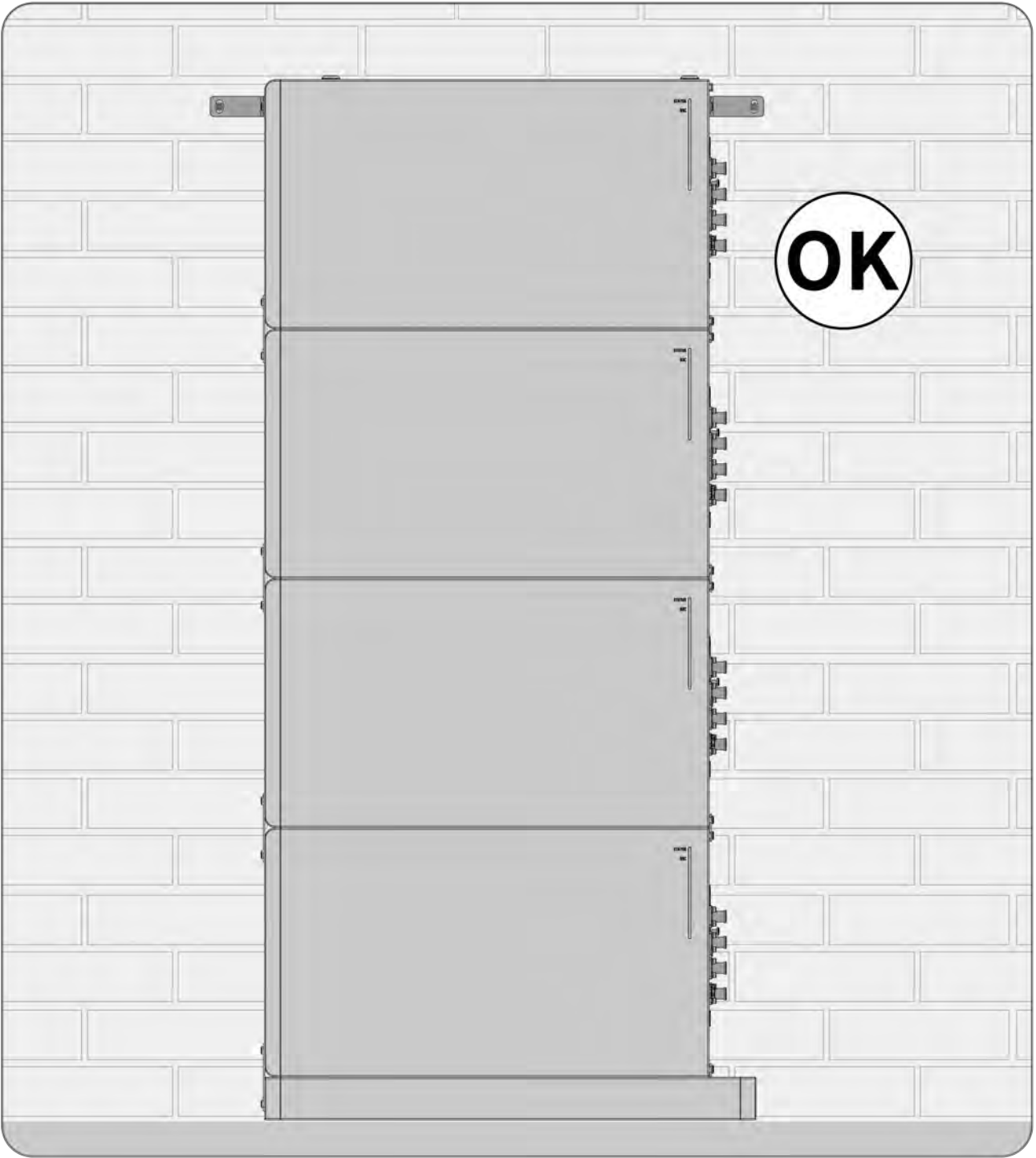

Complete the installation.

6 Electrical connection

6.1 Overview of the connection area

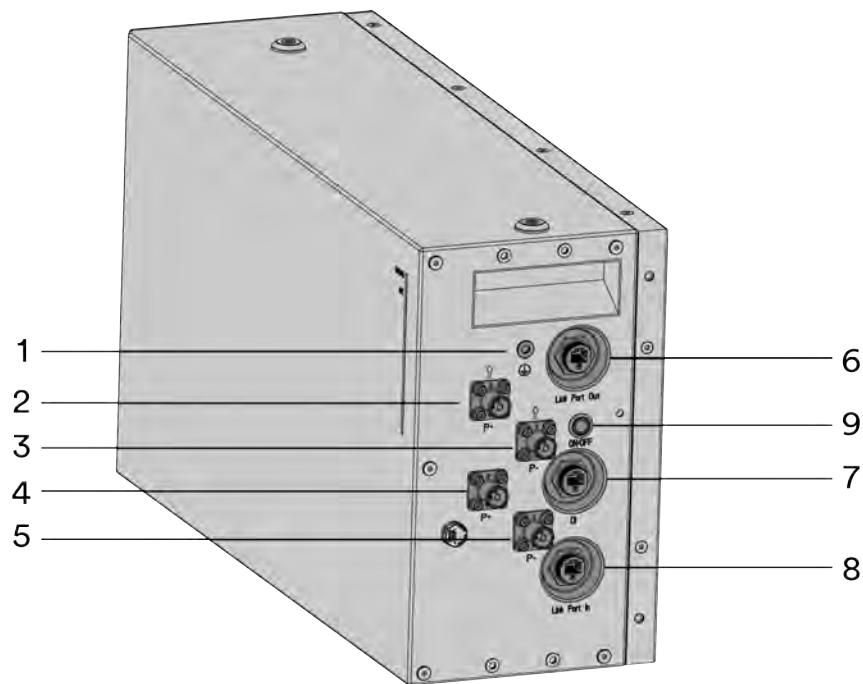

Figure shown here is for reference only. The actual product received may differ!

Object	Description
1	Grounding
2	P+
3	P-
4	P+
5	P-
6	Link port out
7	DI
8	Link port in
9	On/Off

6.2 Connecting the grounding conductor

Procedure:

Step 1: Ensure the the ON/OFF button switch of the battery is OFF.

Step 2: Use the ground cable provided. Fix the grounding terminal by the screw(M6×16) with a phillips-screwdriver and tighten (torque: 6 N.m).

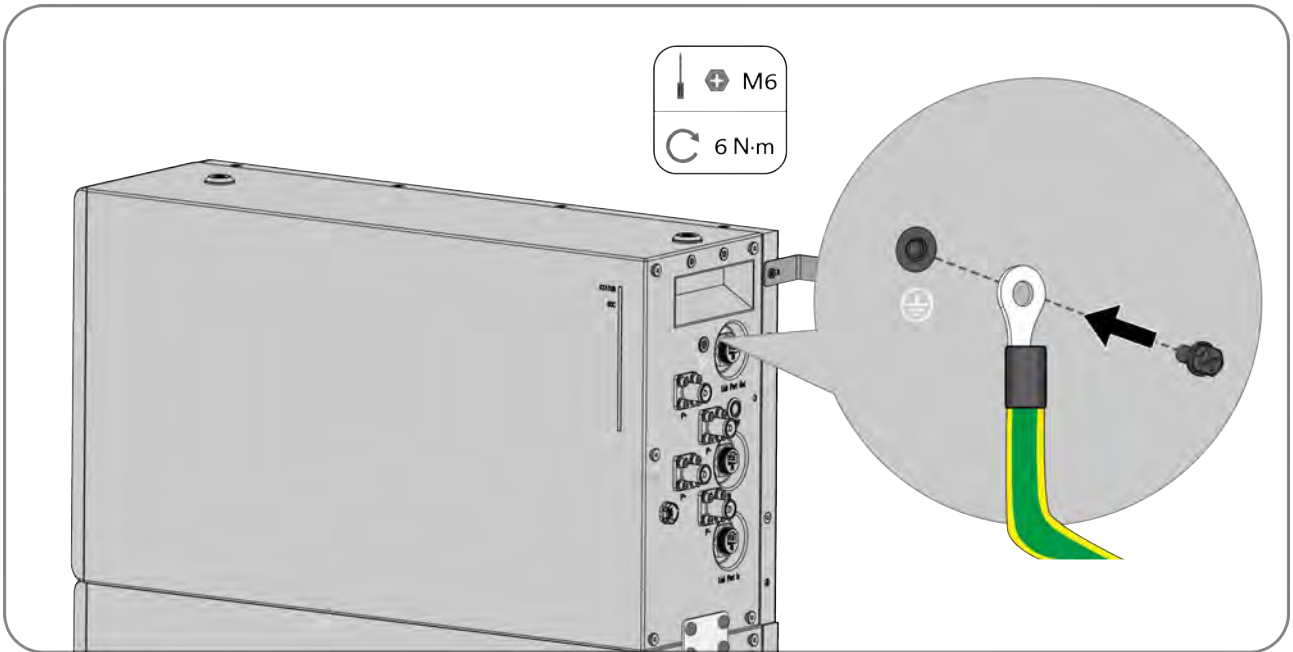

Complete the installation.

6.3 Connecting the power cable and network cable

1-4 modules connection with only one set of output cable (120A max)

Step 1: Connect the battery P+/P- to the hybrid with the supplied output power cables(2m) (black negative cable connect to the **top** battery P- terminal, red positive cable connect to the **bottom** battery P+ terminal). Connect the parallel connection power cable between the stackable batteries like the figure below (red cable connect to the P+ terminal, black cable connect to the P- terminal).

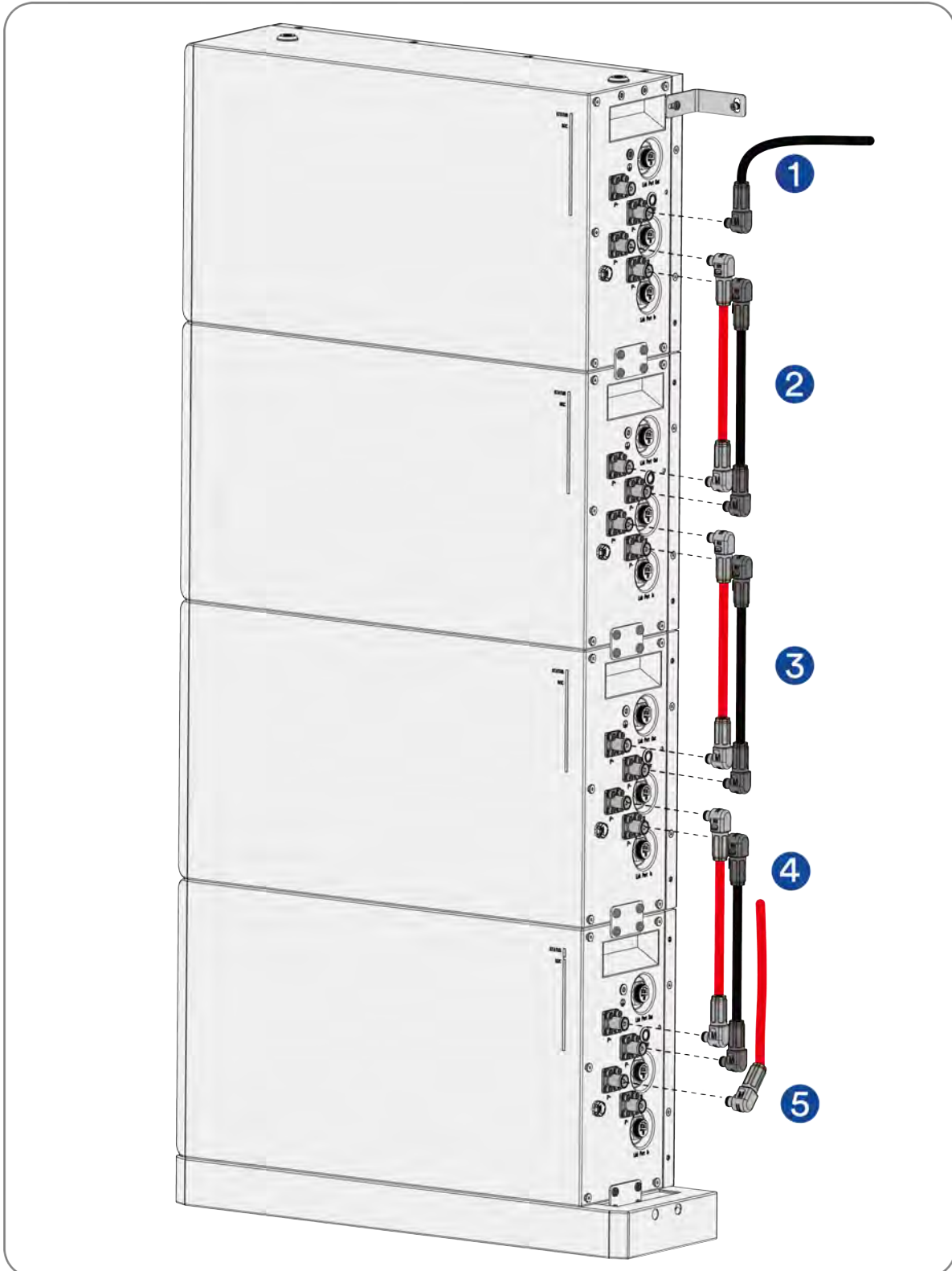

Step 2: Connect the "Link Port Out" of the top battery to the BMS port of the hybrid withing the supplied output communication cable(2m). Connect the "Link Port In" and "Link Port Out" between the stackable parallel batteries using the supplied parallel communication cable. Connect the bottom battery "Link Port In" with the supplied terminal resistor.

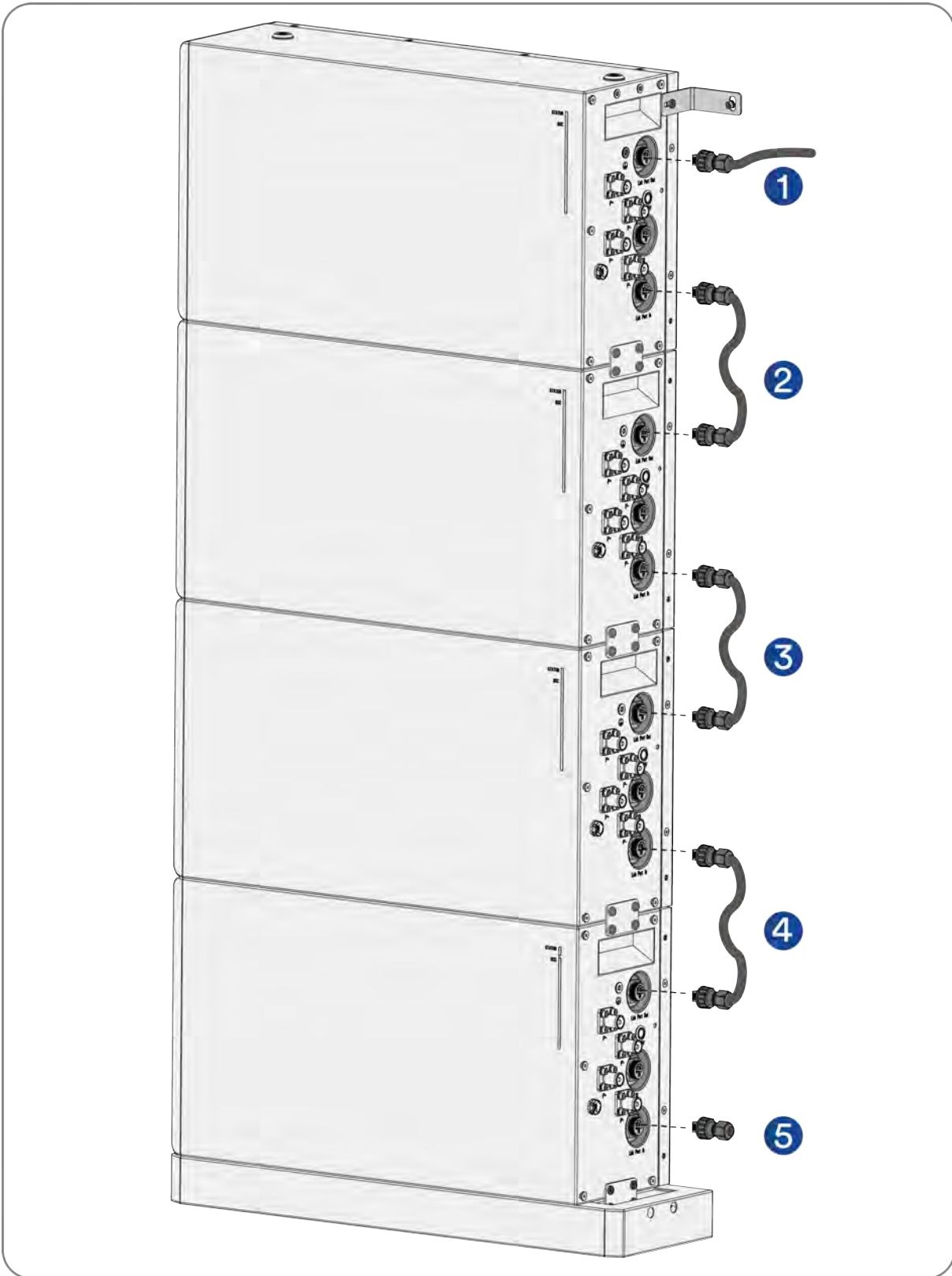

The complete connection is shown below:

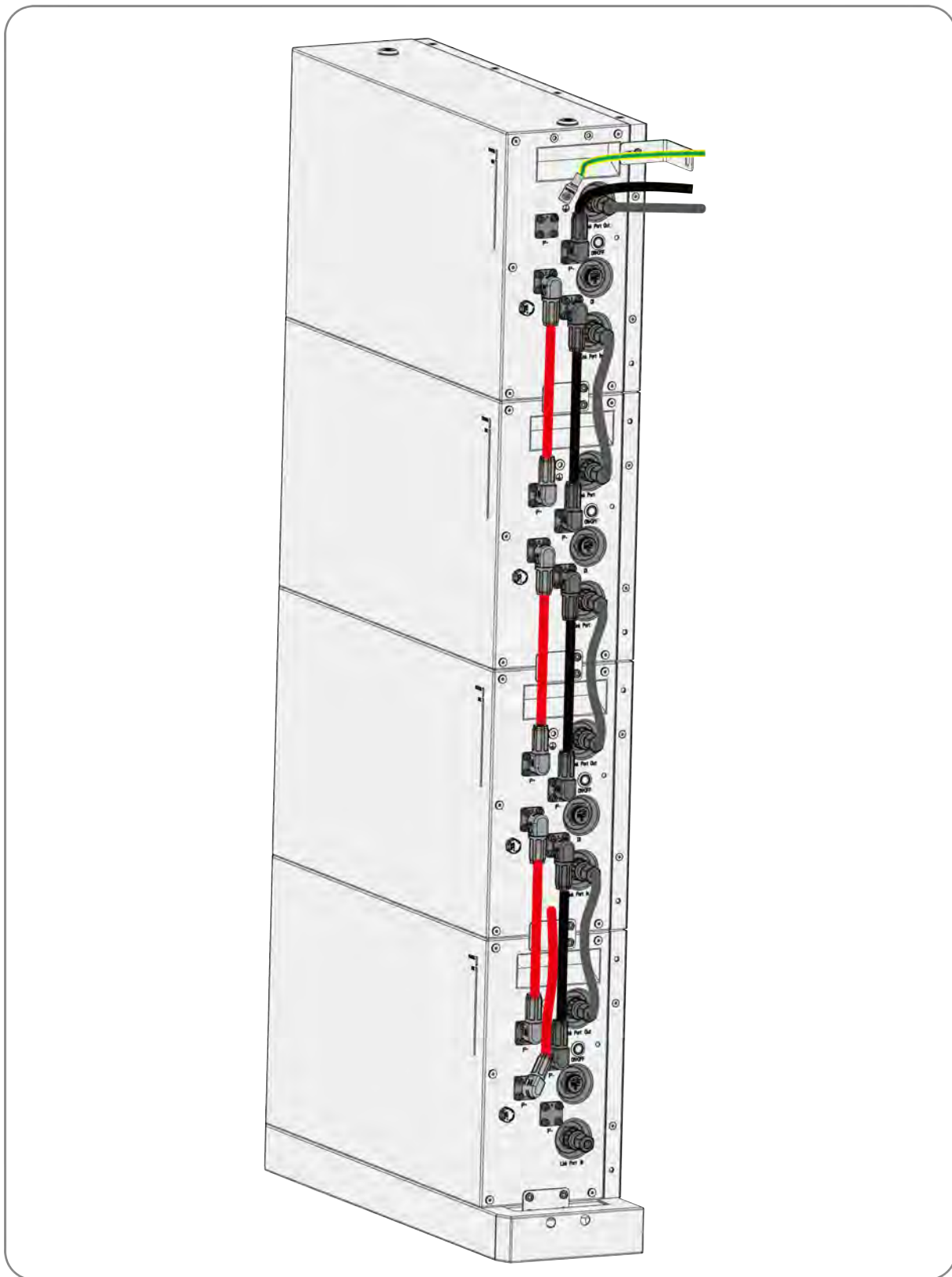

3-4 modules connection with two sets of output cables in parallel (210A max)

Step 1: Connect the battery P+/P- to the hybrid with the supplied output power cables(2m) and optional output power cable(3m) (black negative cable connect to the top battery P- terminal with 2m cable and bottom battery P- terminal with 3m cable, red positive cable connect to top battery P+ terminal with 2m cable and bottom battery P+ terminal with 3m cable). Connect the parallel connection power cable between the stackable batteries like the figure below (red cable connect to the P+ terminal, black cable connect to the P- terminal).

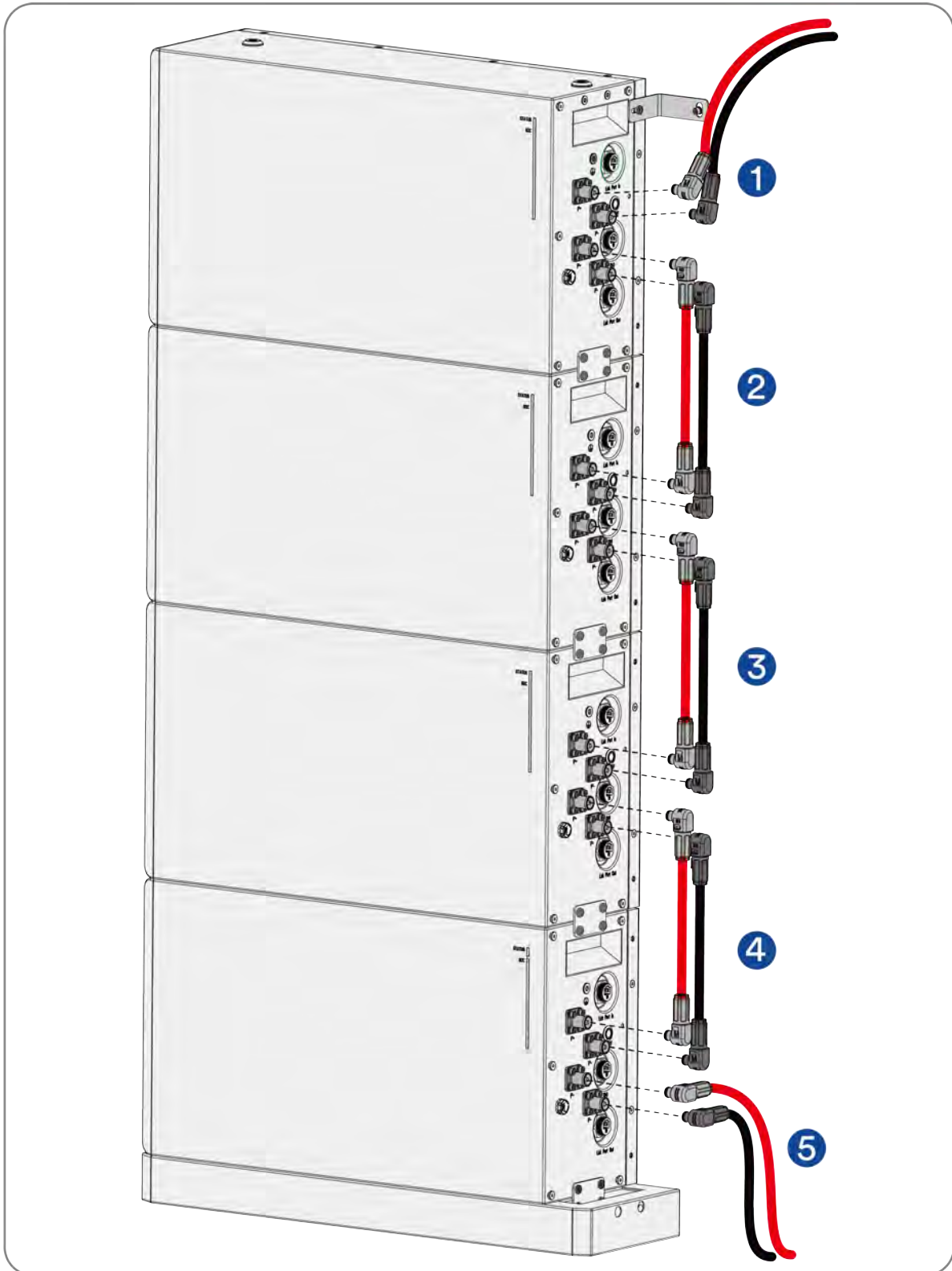

Step 2: Connect the "Link Port out" of the uppermost module of the battery to the battery port of the inverter using a supplied communication output cable. Connect "Link Port out" and "Link Port in" of the battery mid-layer modules using the supplied parallel communication cable. Use a supplied terminal resistor to block the "Link Port in" the lowest module of the battery.

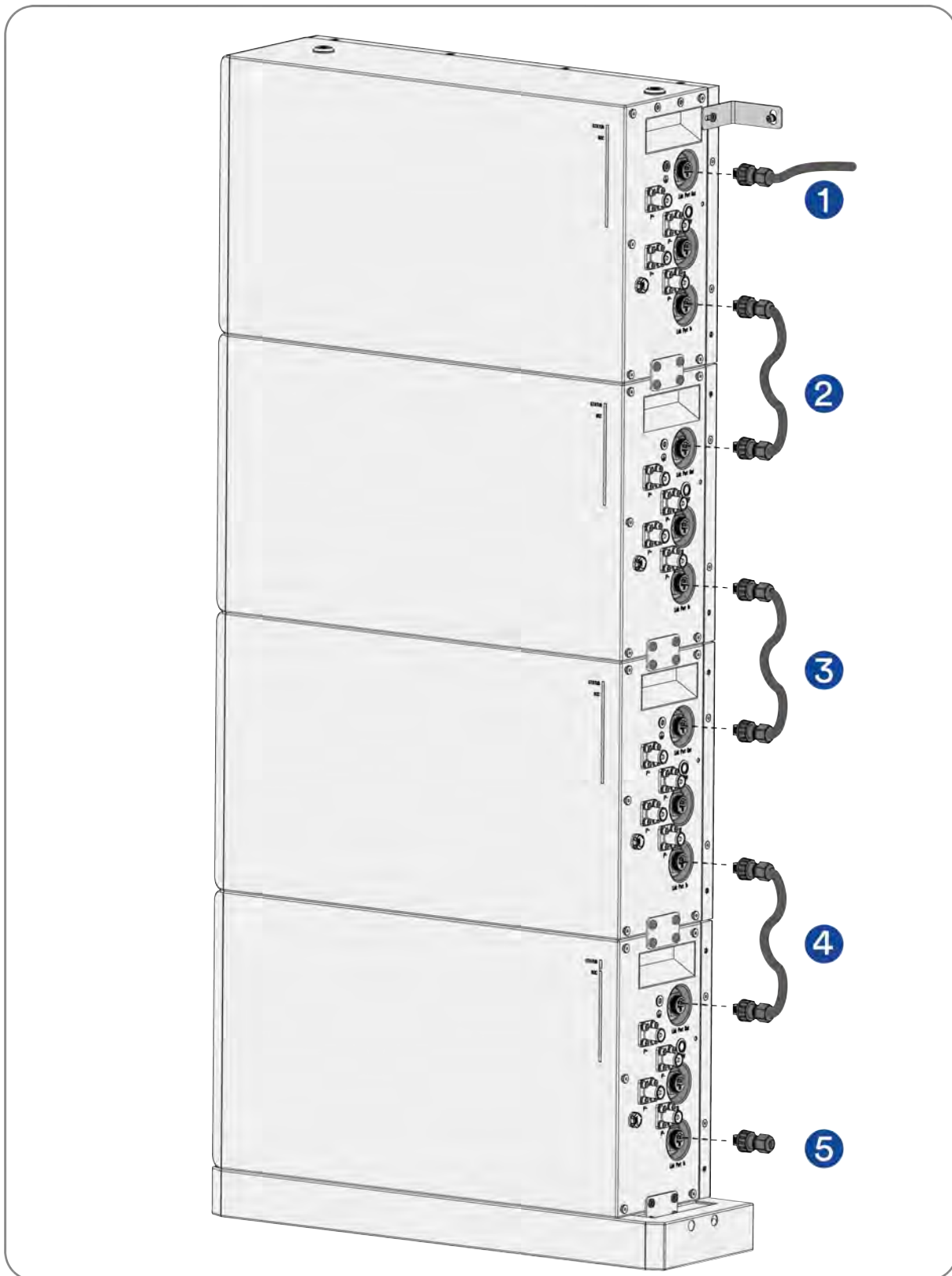

The complete connection is shown below:

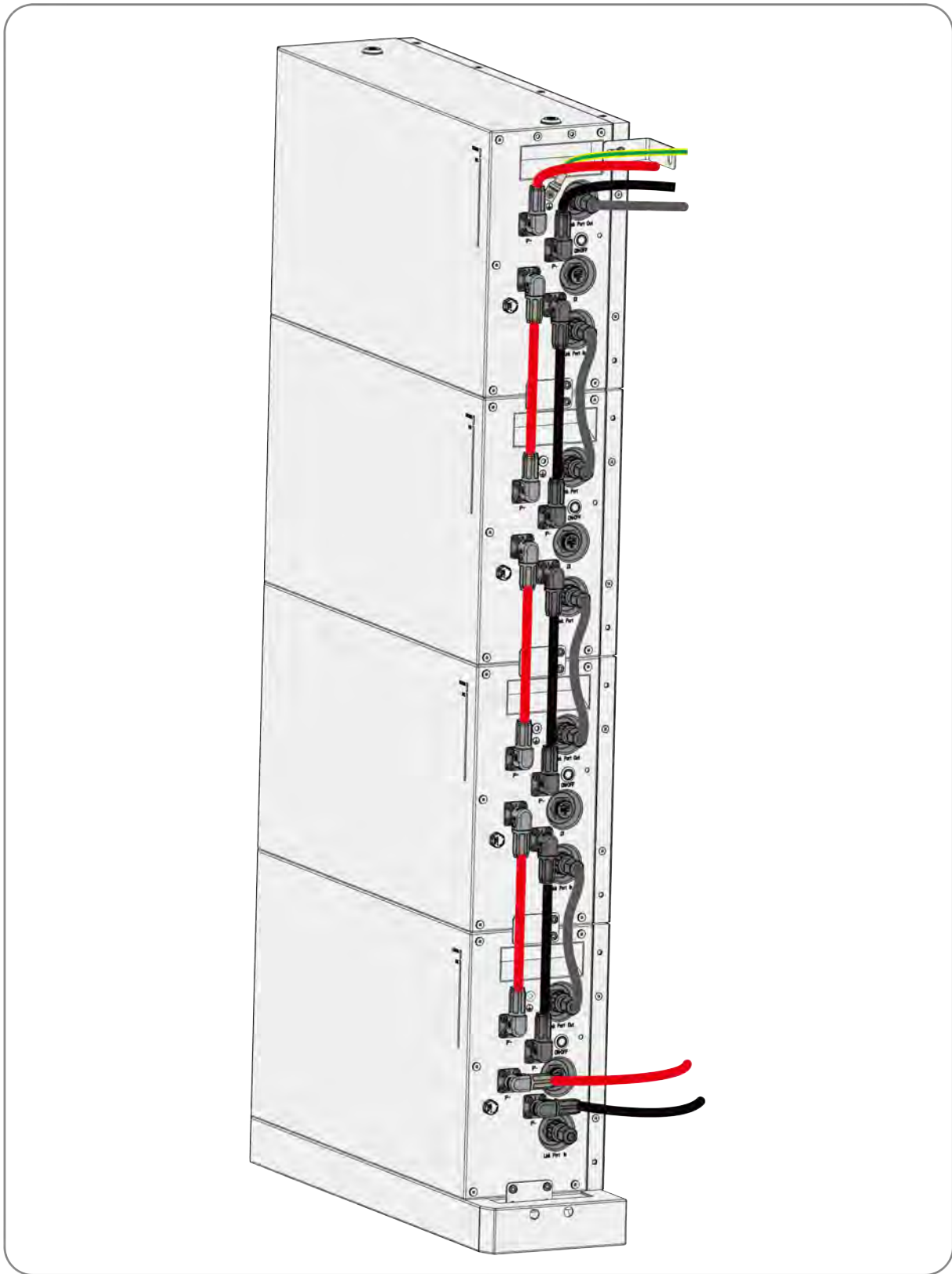

Step 3: Cut the cable hole according to the wiring mode.

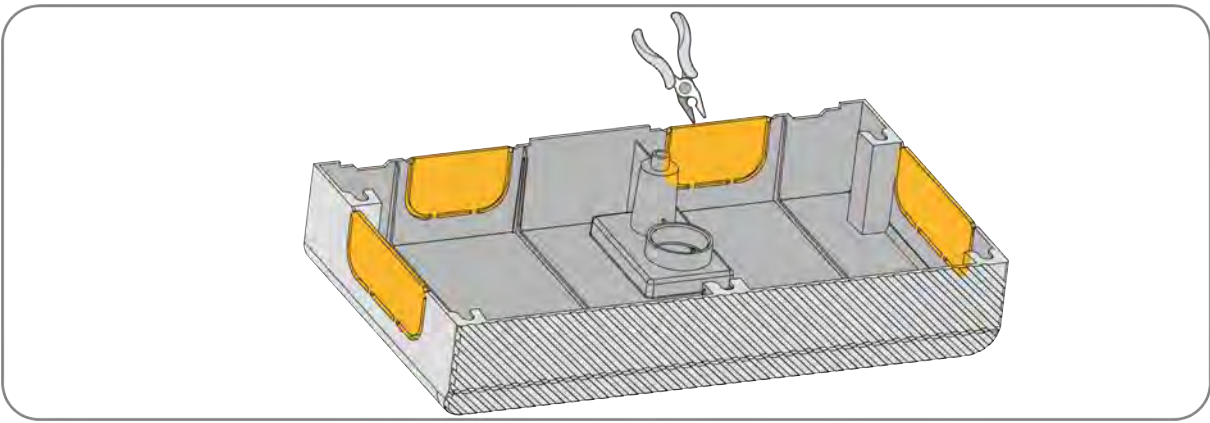

Step 4: Align the decorative covers with the cable area of the battery modules, cover all the cables, and push in the direction of the battery modules so that it is tight to the battery modules. Push the decorative covers backward so that the bayonet on the inside of the decorative covers sticks out of the circle on the battery modules.

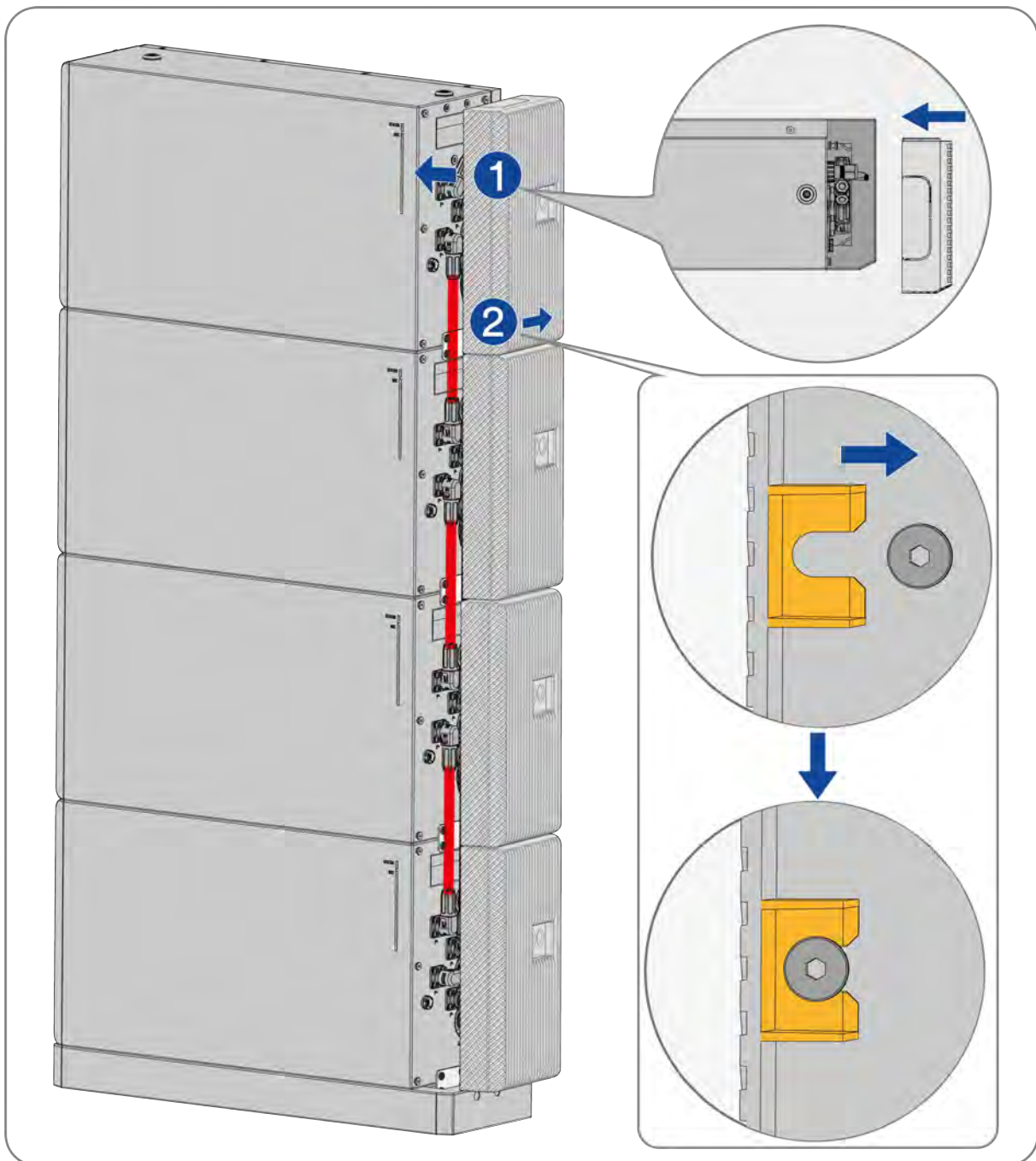

Step 5: Secure the decorative covers by the supplied screws(M5x16). Tightening torque: 4 N.m.

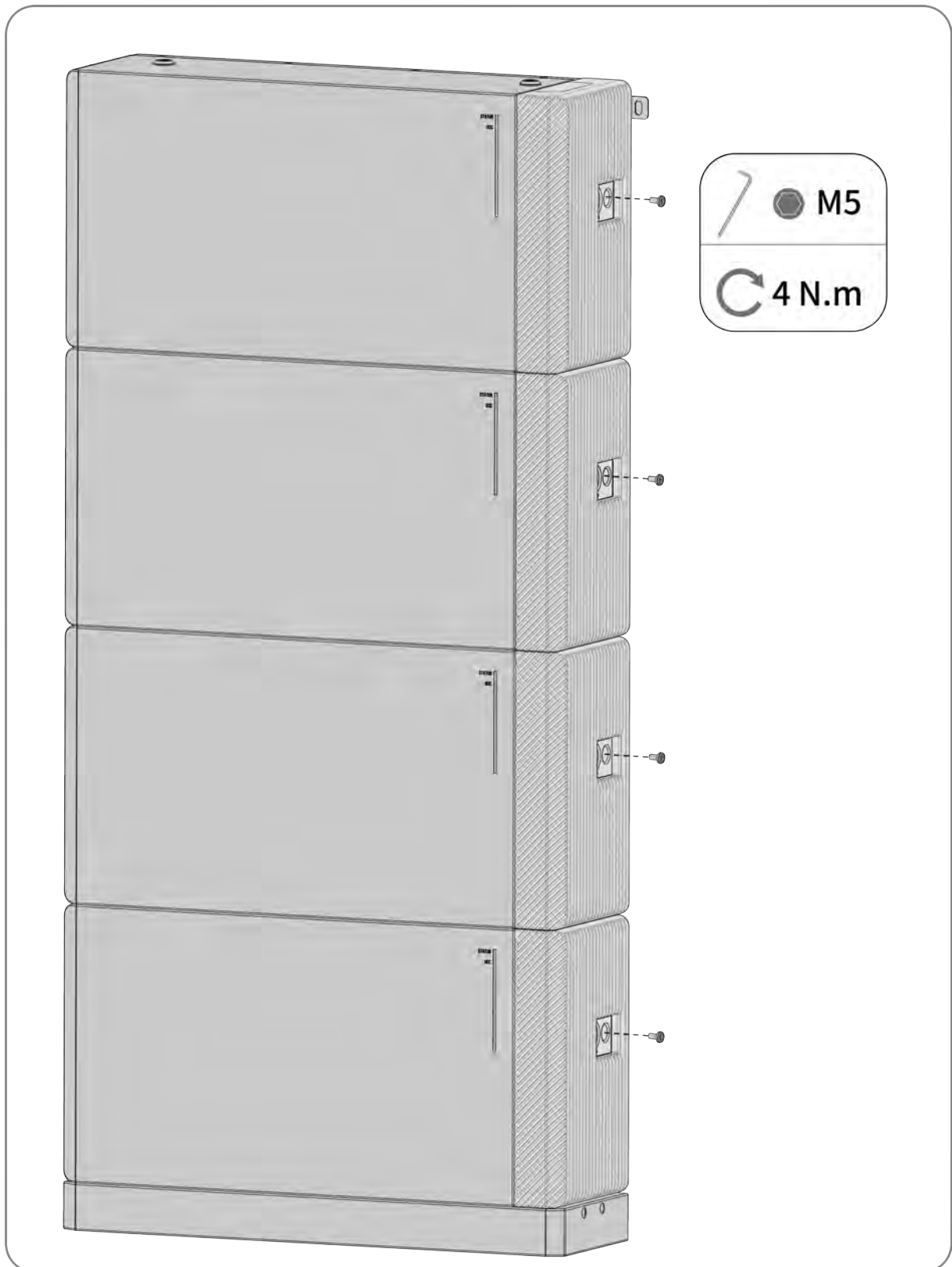



Complete the installation.

6.4 System wiring Diagram

Single system connection diagram

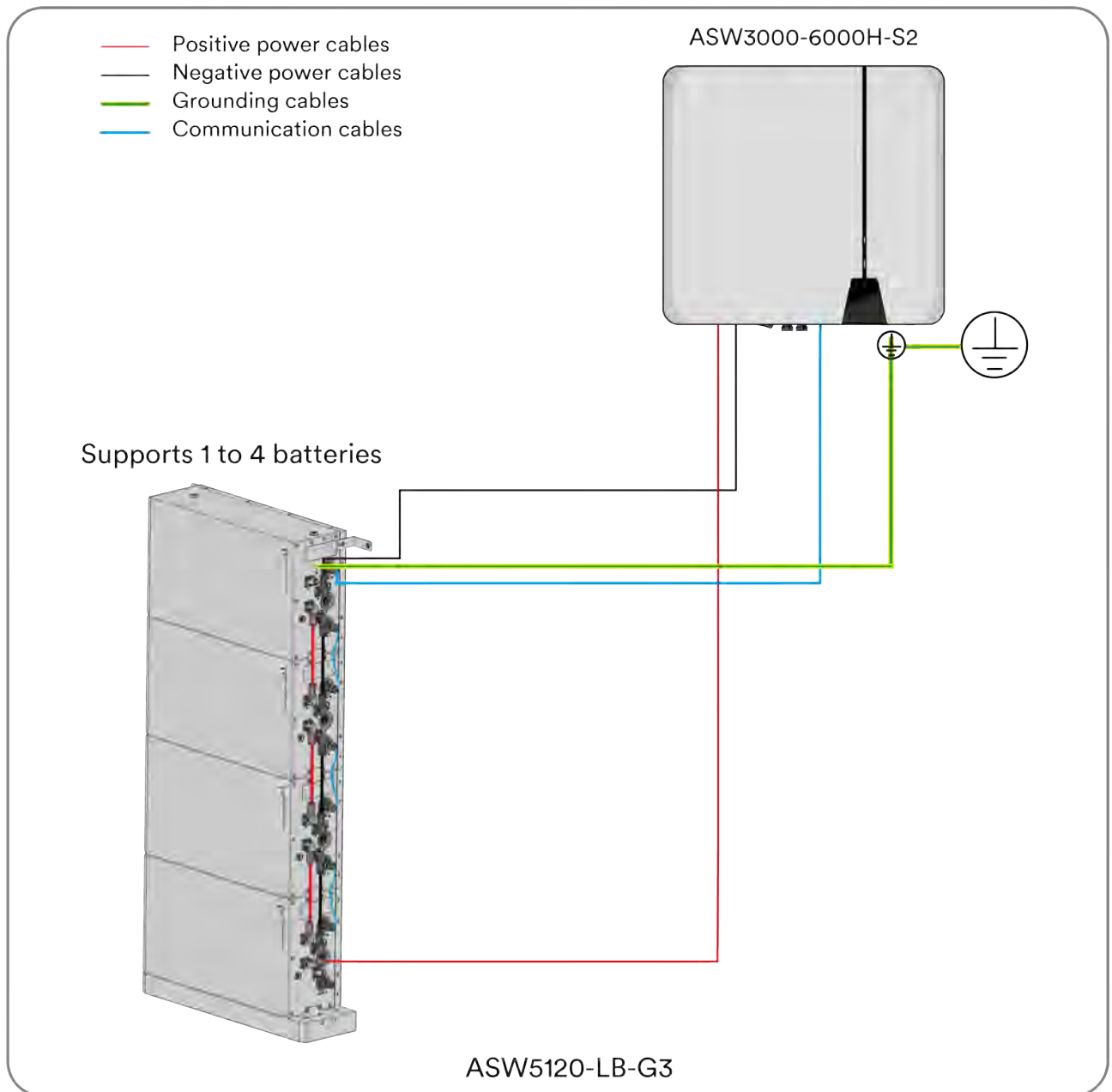

- Positive power cables
- Negative power cables
- Grounding cables
- Communication cables

ASW008-010K-SH

Supports 1 to 4 batteries

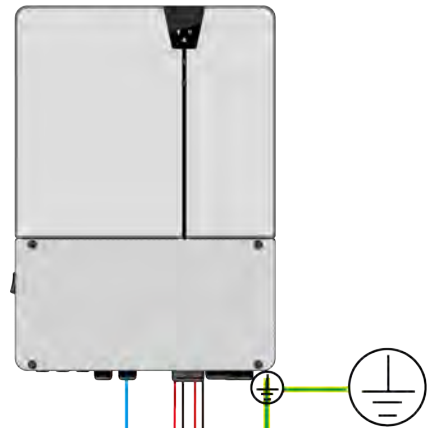

ASW5120-LB-G3

Parallel system connection diagram

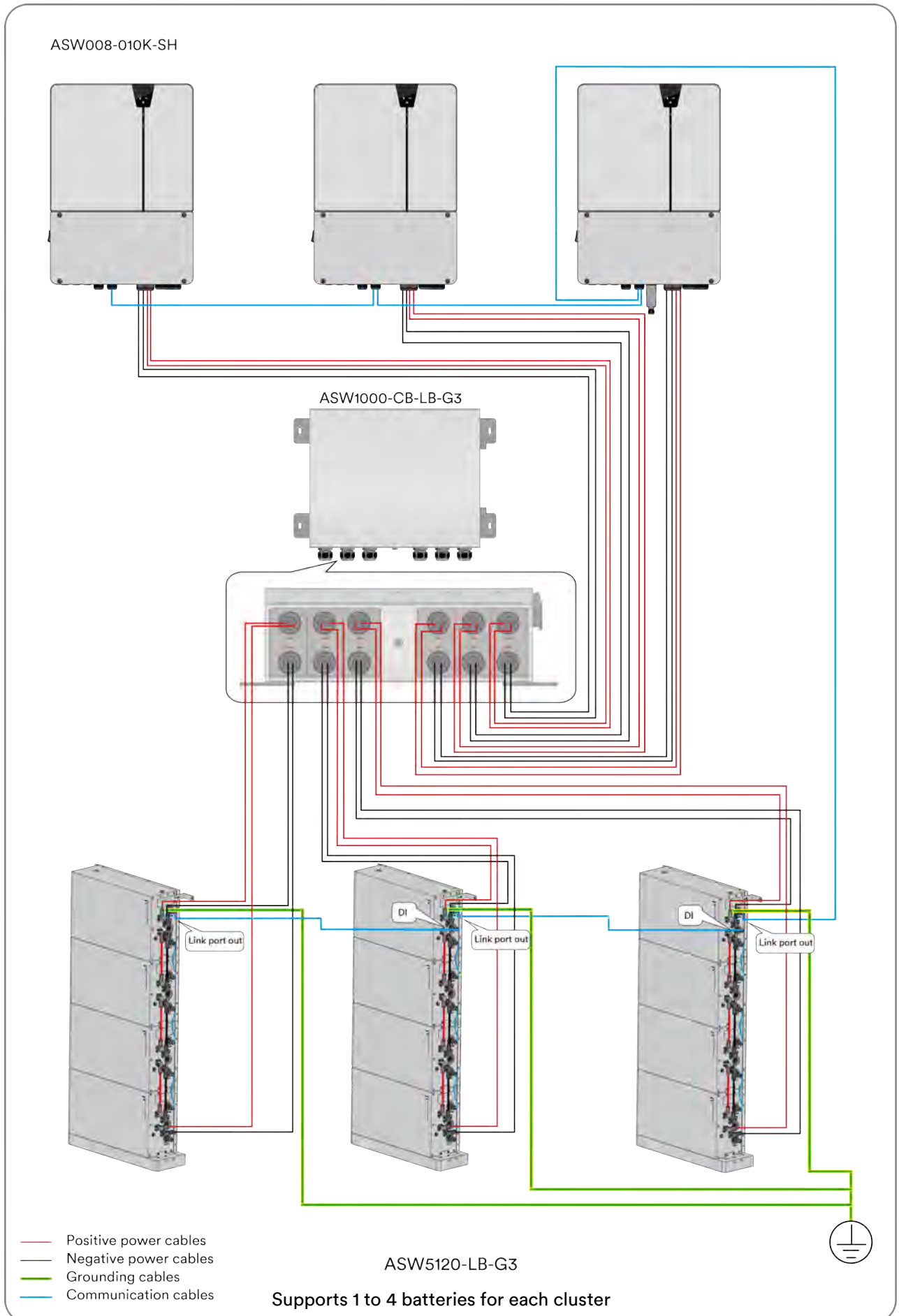

7 Commissioning and operating

7.1 Inspection before commissioning

Check the following items before commissioning the BESS:

- Ensure inverter is compatible with the battery.
- Ensure the inverter is correctly mounted as per Solplanet's guidelines, please refer to the inverter manual.
- Ensure the battery is properly installed and secured in accordance with this manual.
- Ensure the circuit breaker between the battery system and the inverter is off.
- Ensure the communication cables and DC cables are correctly and securely connected.
- Ensure the ground terminal on the BESS is grounded.
- Ensure the DC power cables have been installed with the correct polarity.

7.2 Commissioning procedure

If all of the items mentioned above have been met then proceed as follows to commission and start-up the battery for the first time:

Step 1: Press the ON/OFF button for 1s, **after releasing the button then** all lights will turn on from bottom to top, and the BESS will enter into working mode.

Step 2: Check whether the battery indicator of the inverter is on.

Step 3: Start inverter according to inverter start-up procedure.

Step 4: Commission the inverter according to the inverter commissioning procedure using the Solplanet App.

Step 5: Read the battery status information using the Solplanet App and confirm that the BESS is communicating with the inverter, observe the LED's on the BESS to determine the current status.



Recommended standard charging and discharging procedure as follow:

- Charging at a constant current with 0.6C until the SOC reach to 95%, and then charging to 100% SOC with 0.3C at 25°C.
- Discharging at a constant current with 0.6C until the SOC reach to 0% at 25°C.

8 Decommissioning the product

CAUTION

Risk of injury due to weight of the battery module!

Injuries may result if the battery module is lifted incorrectly or dropped while being transported or installed.

- Transport and lift the battery module carefully. Take the weight of the battery module into account.
- • Wear suitable personal protective equipment for all work on the battery system.

DANGER

Danger to life from electric shock due to live DC cables or conductors at the battery system !

The DC cables connected to the battery system may be live. Touching the DC conductors or the live components leads to lethal electric shocks..

- Do not touch non-insulated cable ends.

Procedure:

Step 1: Switch off the inverter by first turning off the AC circuit breaker downstream of the AC output of the inverter and second by turning off the inverter DC switch.

Step 2: Switch off the BESS.

Step 3: Switch off the any external DC switches between the inverter and the BESS if there are any.

Step 4: Loosen the decorative cover screws and remove the decorative cover.

Step 5: Remove all cables from the BESS.

Step 6: Loosen the screws on L-brackets between the battery system and the wall and remove the L-brackets.

Step 7: Loosen the screws between the battery module and the base, and remove the anti-tipping supports on the left and right sides.



Before lifting the battery module, ensure that the screws on both sides of them are removed.

Step 8: Remove the battery module and battery base in sequence.

If the battery system is to be stored or shipped, pack the system using the original packaging or packaging that is suitable for the weight and dimensions of the system.

Dispose of the battery system in accordance with the locally applicable battery disposal regulations.

9 Technical data

Model		ASW5120-LB-G3			
Module quantity		1	2	3	4
Nominal Energy*1		5.12 kWh	10.24 kWh	15.36 kWh	20.48 kWh
Nominal Voltage		51.2V			
Operating Voltage		40 V ~ 58.4 V			
Dimension (W*D*H)		630*185 *320 mm	630*185 *640 mm	630*185 *960 mm	630*185 *1280 mm
Battery weight		48.6 kg	94.6 kg	140.6 kg	186.6 kg
Modules weight		46 kg	92 kg	138 kg	184 kg
Base weight		2.6 kg			
Max. Continuous charging current		60 A	120A	180A	210A
Max. Continuous discharging current		100 A	200A	210A	210A
Communication		CAN			
Operating temperature		Charge: -8 °C ~ 58°C Discharge: -18°C ~ 58°C			
Ingress protection rating		IP66			
Display		SOC and status indicator, LED indicator			
Installation		Indoor/Outdoor			
Max. Operating altitude		4000 m (>3000 m derating)			
Relative humidity		5%~95%RH, no condensing			
Cooling		Natural convection			
Cell type		Lithium-iron phosphate (LiFePO4)			
Life cycle		6000 times*2			
Round-trip efficiency		≥95%			
Standard and Certification	Safety	IEC62619, IEC62040-1, IEC62477-1, IEC60730, IEC63056			
	EMC	IEC61000-6-1, IEC61000-6-3, IEC61000-6-2, IEC61000-6-4			
	Transportation	UN38.3			

*1. Nominal energy is defined under the following conditions: battery voltage 40~58.4V, 0.5C charge & discharge at +25°C.

*2. Life cycle is defined under the following conditions: 90% DOD, 70% EOL, 0.5C charge & discharge at 25°C (One cycle a day).

10 Troubleshooting

When the yellow LED indicator solid on, it indicates that the battery is in an alarm state.

When the red LED indicator solid on, it indicates that the battery is in an fault state.

When the yellow LED indicator blinking, it indicates that the battery communication loss.

If the red indicator is constant, the battery is faulty. Turn off the battery immediately and contact the manufacturer for after-sales service.

11 Maintenance

Cleaning

It is recommended that the battery system be cleaned periodically. If the enclosure is dirty, please use a soft, dry brush or a dust collector. Liquids such as solvents, abrasives, or corrosive liquids should not be used to clean the enclosure.

Maintenance

The battery module should be stored in an environment with a temperature range between -20°C ~ $+45^{\circ}\text{C}$ and charged regularly according to the table below with no more than 0.5C to the SOC of 50% after a long time of storage.

Temperature	Relative humidity	Storage time	Original SOC
Below -20°C	/	Not allowed	/
$0\sim 25^{\circ}\text{C}$	35%~85%	≤ 6 months	$25\% \leq \text{SOC} \leq 50\%$
$-20\sim 45^{\circ}\text{C}$	35%~85%	≤ 1 months	$25\% \leq \text{SOC} \leq 50\%$
Above 45°C	/	Not allowed	/

NOTICE

Damage to the system due to under voltage!

- Charge the over-discharged system within seven days when the temperature is above 25°C .
- Charge the over-discharged system within fifteen days when the temperature is below 25°C .

12 Recycling and disposal

Dispose of the packaging and replaced parts according to the rules applicable in the country where the device is installed.



Do not dispose of the product together with the household waste but in accordance with the disposal regulations for electronic waste applicable at the installation site.

13 EU declaration of conformity

Within the scope of the EU directives:

-Electromagnetic compatibility directive 2014/30/EU

(L 96/79-106, March 29, 2014)(EMC)

-Low voltage directive 2014/35/EU (L 96/357-374, March 29, 2014)(LVD)

Restriction of the use of certain hazardous substances 2011/65/EU

(L 174/88, June 8, 2011) and 2015/863/EU (L 137/10, March 31, 2015) (RoHS)

AISWEI New Energy Technology (Yangzhong) Co., Ltd. confirms here with that the products described in this document are in compliance with the fundamental requirements and other relevant provisions of the above mentioned directives.

The entire EU Declaration of Conformity can be found at www.solplanet.net.



14 Service and warranty

If you have any technical problems concerning our products, please contact Solplanet service.

We require the following information in order to provide you with the necessary assistance:

- Battery serial numbers
- Battery type and model
- Inverter device type
- Inverter serial number
- Type and number of connected PV modules
- Mounting location
- Installation date

Warranty terms and conditions can be downloaded at www.solplanet.net.

When the customer needs warranty service during the warranty period, the customer must provide a copy of the invoice, factory warranty card, and ensure the electrical label of the battery is legible. If these conditions are not met, Solplanet has the right to refuse to provide with the relevant warranty service.

15 Contact

EMEA

Service email: service.EMEA@solplanet.net

APAC

Service email: service.APAC@solplanet.net

LATAM

Service email: service.LATAM@solplanet.net

AISWEI Pty Ltd.

Hotline: +61 390 988 674

Add.: Level 40, 140 William Street, Melbourne VIC 3000, Australia

AISWEI B.V.

Hotline: +31 208 004 844 (Netherlands)

+48 134 926 109 (Poland)

Add.: Barbara Strozziilaan 101, 5e etage, kantoornummer 5.12, 1083HN Amsterdam, the Netherlands

AISWEI Technology Co., Ltd

Hotline: +86 400 801 9996

Add.: Room 904 - 905, No. 757 Mengzi Road, Huangpu District, Shanghai 200023



