



Ai-LB 10K Pro

Installation Manual

Contents

1	General information	1
1.1	About this document.....	1
1.2	Product validity.....	1
1.3	Target group	1
1.4	Symbols.....	2
2	Safety.....	3
2.1	Intended use.....	3
2.2	Important safety instructions.....	3
2.3	Symbols on the label	4
3	Unpacking and storage.....	5
3.1	Scope of delivery	5
3.2	Product storage	6
4	Product overview	7
4.1	Dimensions	7
4.2	Interfaces and functions	7
4.3	Basic system solution	9
5	Mounting.....	10
5.1	Requirements for mounting.....	10
5.2	Mounting	13
6	Electrical connection	16
6.1	Requirements for the Electrical connection.....	16
6.2	Single Unit Connection.....	18
6.3	Ground Connection.....	18
6.4	Communication Connection.....	19
6.5	Power Cable Connection	20
6.6	Turn On Battery	20
6.7	Shutdown Battery	21
6.8	Multi-Unit Connection with Bus-Bars (3-unit example)	22
6.9	Multi-Unit Connection without Bus-Bars (3-unit example)	23
7	Commissioning.....	25
7.1	Inspection before commissioning.....	25

7.2	Commissioning procedure	25
8	Decommissioning the product	26
9	Technical data	27
10	Handling Precautions and Guidelines for Product	28
11	Maintenance	30
12	Recycling and disposal	31
13	EU declaration of conformity	31
14	Service and warranty	31
15	Contact	32

1 General information

1.1 About this document

This document describes the mounting, installation, commissioning, configuration, operation, troubleshooting and decommissioning of the Ai-LB Pro battery energy storage system (BESS).

You will find the latest version of this document and further information on the BESS in PDF format at www.solplanet.net.

It is recommended that this document be readily accessible at all times.

1.2 Product validity

This document is valid for the following models:

- Ai-LB 10K Pro

1.3 Target group

This document is intended for qualified persons who must perform the tasks exactly as described in this user manual.

All installation work must be performed by appropriately trained and qualified persons.

Qualified persons must possess the following skills:

- Knowledge of how batteries work and are operated.
- Knowledge of how an inverter works and is operated.
- Training in how to deal with the dangers and risks associated with installing, repairing and using electrical devices and batteries and installations.
- Training in the installation and commissioning of electrical devices.
- Knowledge of all applicable laws, standards and directives.
- Knowledge of and compliance with this document and all safety information.

Not adhering to the prescribed instructions may potentially void the manufacturer's warranty. If in doubt, please contact the local Solplanet service team.

1.4 Symbols

DANGER

Indicates a hazardous situation which, if not avoided, will result in death or serious injury.

WARNING

Indicates a hazardous situation which, if not avoided, could result in death or serious injury.

CAUTION

Indicates a hazardous situation which, if not avoided, could result in minor or moderate injury.

NOTICE

Indicates a situation which, if not avoided, can result in property damage.



Information that is important for a specific topic or goal, however not related to safety.

2 Safety

2.1 Intended use

The Ai-LB 10K Pro is a BESS is for both residential and commercial applications and operates with Solplanet hybrid inverters. The product is intended for indoor applications.

- It is a low voltage Li-ion BESS.
- It can be operated in on-grid, off-grid and backup modes with all officially compatible Solplanet inverters.
- The product is suitable for indoor and outdoor use.
- The product must only be used as stationary equipment.
- Alterations to the product are not allowed unless authorized in writing by Solplanet.
- Unauthorized alterations will void the guarantee and warranty claims. Solplanet will not be held liable for any damage caused by such unauthorized alterations.
- The product is not suitable for supplying power to life-sustaining medical devices.
- Please ensure that no personal injury would lead due to the power outage of the battery system.
- The product must only be used in countries for which it is approved for by Solplanet.
- Use this product only in accordance with the information provided in this documentation and with the locally applicable standards and directives. Any other application may cause personal injury or property damage.
- The type label must remain permanently attached to the product.
- This document does not replace any regional, state, provincial, federal or national laws, regulations or standards that apply to the installation, electrical safety and use of the product.

2.2 Important safety instructions

The product has been designed and tested strictly according to the international safety requirements. As with all electrical or electronical devices, there are residual risks despite careful construction. To prevent personal injury and property damage and to ensure long-term operation of the product, read this section carefully and observe all safety information at all times.

DANGER

Danger to life due to electric shock where surge protection is not used !

If there is no surge protection, a voltage surge can be conducted into the building and to other connected devices in the same system through power cables, network cables or other types of cable. Touching live parts and cables may result in death or lethal injury due to electric shock.

- Ensure all devices in the same system and the inverter are integrated within an existing surge protection systems/devices.
- Refer to local installation regulations to determine the requirements for the installation of surge protection devices.

WARNING

Danger to life due to electric shock from destruction of measurement devices due to overvoltage !

Overvoltage can damage a measurement device and result in voltage being present in the enclosure of the measurement device. Touching the live enclosure of the measuring device results in death or lethal injuries due to electric shock.

- Only use measuring devices with a higher voltage range than the system battery voltage.

WARNING

Risk of injury due to weight of product !

Injuries may result if the product is lifted incorrectly or dropped while being transported or mounted.

- Lift and transport the product carefully.
- Wear suitable personal protective equipment, in accordance with local regulations, when working on the product.

NOTICE

Damage to the battery system due to electrostatic discharge !

Internal components of the battery system can be irreparably damaged by electrostatic discharge.

- Ground yourself before touching any component.

2.3 Symbols on the label



Beware of a danger zone!

This symbol indicates that the product must be additionally grounded if additional grounding or equipotential bonding is required at the installation site.



Beware of high voltage and operating current!

The product operates at a high voltage and current. Work on the product must only be carried out by skilled and authorized personnel.



WEEE Designation

Do not dispose of the product together with household waste. Dispose the product in accordance with local disposal regulations for electronic waste



CE marking

The product complies with the requirements of the applicable EU directives.



The battery is recyclable

The battery can be recycled by a professional recycling organization, please refer to the relevant local regulations.



Observe the documentation

Read and understand all documentation supplied with the product.



ROHS marking

The EU material and process standards for electrical and electronic products make them more conducive to human health and environmental protection.



UKCA marking

The product complies with the requirements of the applicable UK Product Directive.

3 Unpacking and storage

3.1 Scope of delivery

Check the scope of delivery for completeness and any visible external damage. Contact your supplier if the package is damaged upon delivery or is incomplete or damaged.

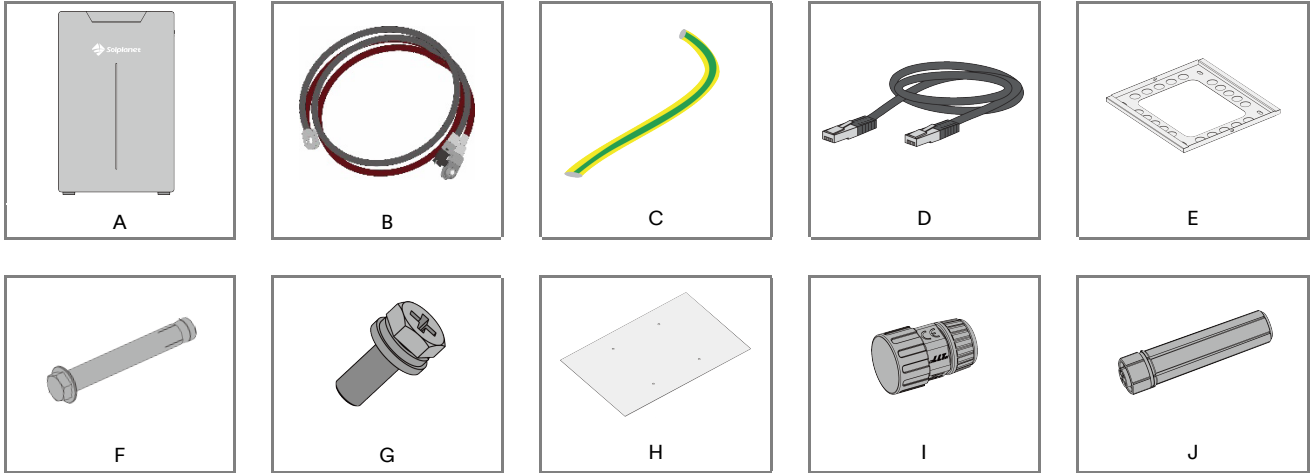

Object	Item Name	Details	Quantity	Notes
A	Battery	Ai-LB 10K Pro 550x165x867 mm 21.651x6.50x31.21 in	1	
B	Power Cable	Positive: orange plug, 35 mm ² / 2 AWG, L:1.5 m (59.06 in) to SC50-10 ring terminal. Negative: black plug, 35 mm ² / 2 AWG, L:1.5 m (59.06 in) to SC50-10 ring terminal	1 set	Continuous flow capacity: 160A
C	Grounding Cable	Ground cable yellow & green/L:1 m (39.37in)/ double OT M6	1	
D	Communication cable	Standard network cable black/L:1.5 m (59.06 in)/Double RJ45 Plug	1	
E	Mounting Plate		1	
F	Expansion Screw	M8*80 mm	4	
G	Screw	M5*16 mm	2	
H	Mounting Positioning Board		1	
I	RJ45 Water-proof Wiring Terminal		3	
J	Wifi Stick	EESW-A400-02, 98x23x23 mm	1	

3.2 Product storage

Suitable storage is required if the equipment is not installed immediately:

- Store the battery in the original packing case.
- The storage temperature must be between -10°C ~ $+50^{\circ}\text{C}$, and the storage relative humidity must be 5~95% RH, non-condensing.
- The storage SOC: 25%~50%. Re-charge the battery every 6 months, to ensure no over-discharge of the battery occurs.
- The packing with the equipment shall not be tilted or inverted.
- Place the equipment in a cool place away from direct sunlight.
- Keep the equipment away from flammable, explosive, and corrosive materials.
- Keep the equipment away from rain.
- The product must be fully inspected and tested by authorized personnel before it can be put into operation, if it has been stored for three or more months.

4 Product overview

4.1 Dimensions

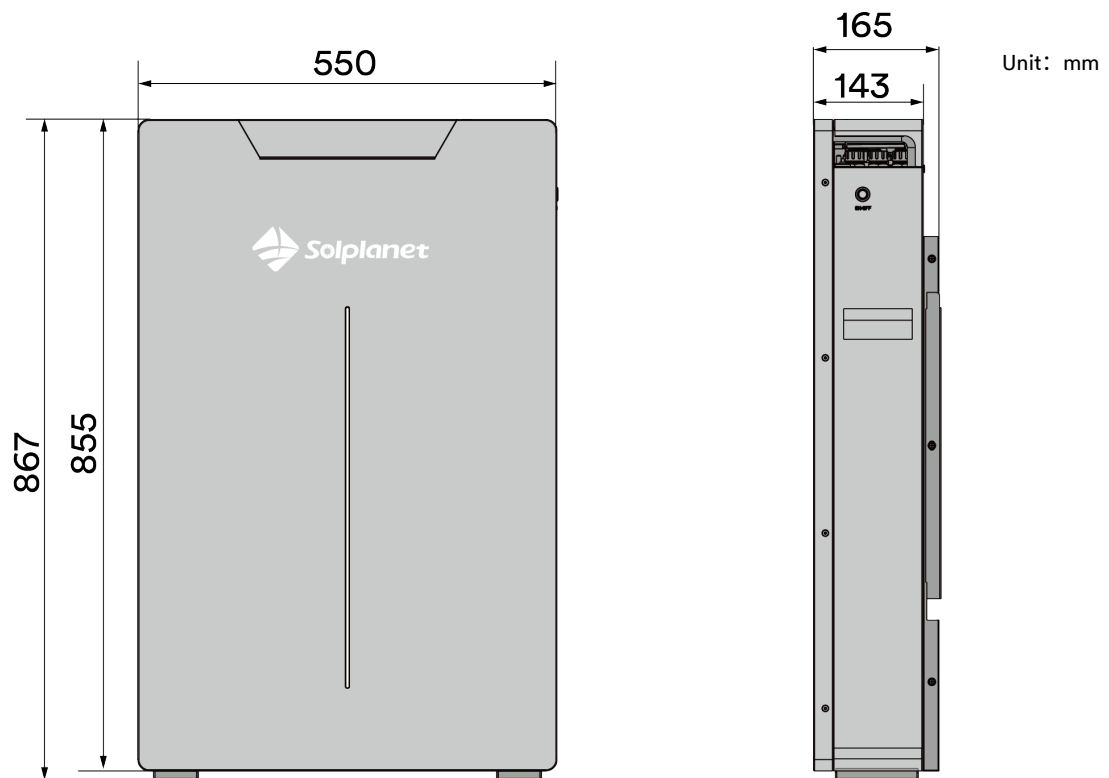

4.2 Interfaces and functions

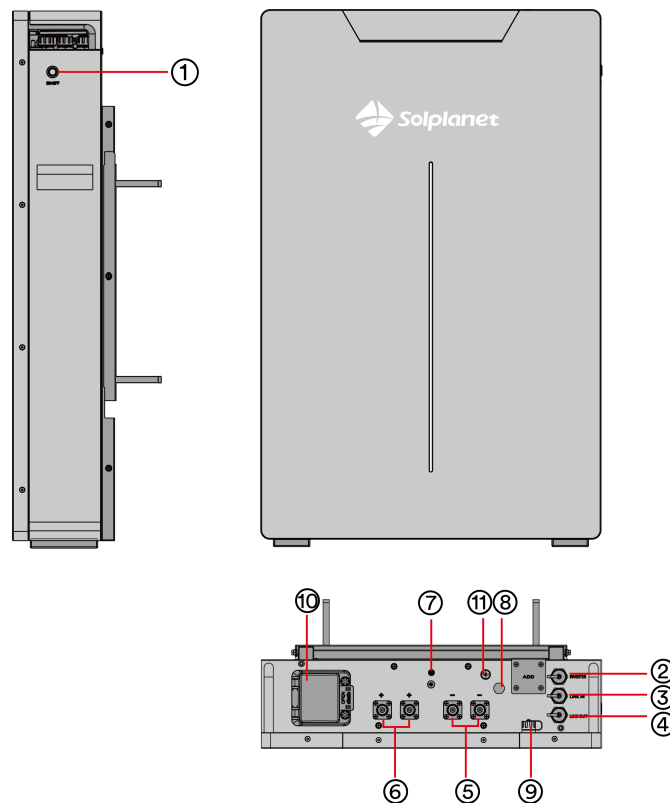

The product is equipped with the following interfaces and functions:

Number	Name	Details	Notes
1	Power Switch		Red LED: ALARM, Blue LED: RUN
2	INVERTER	RJ45	CAN communication to the inverter
3	LINK IN	RJ45	Internal RS485 communication between batteries
4	LINK OUT	RJ45	Internal RS485 communication between batteries
5	Port Negative x2	PSR8XAB	Black cable 35 mm ² / 2 AWG, cable plug model: PSRP8XA50, Manufacturer: GENERAL(Suzhou) CO., Ltd.
6	Port Positive x2	PSR8XBB	Red cable 35 mm ² / 2 AWG, cable plug model: PSRP8XB50, Manufacturer: GENERAL(Suzhou) CO., Ltd.
7	GND	M6	Yellow-Green, 10 AWG
8	Venting Valve		
9	WIFI Socket		For WIFI stick
10	125A DC Breaker		
11	Reset Point		In case of severe undervoltage, wake up the battery

RJ45 Port Pin Definition

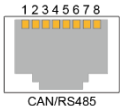
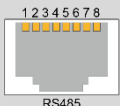
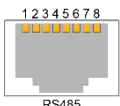
View	Item	Description	1	2	3	4	5	6	7	8
	2	INVERTER	-	RS485-A	RS485-B	CAN-H	CAN-L	GND	-	-
	3	LINK IN	-	BMS-RS485-A	BMS-RS485-B	DI+	DI-	NC	BMS-CAN-H	BMS-CAN-L
	4	LINK OUT	-	BMS-RS485-A	BMS-RS485-B	DO+	DO-	NC	BMS-CAN-H	BMS-CAN-L

WiFi Socket port description

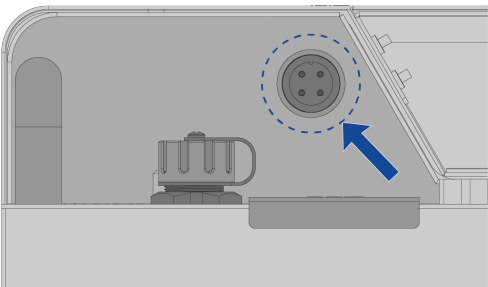
Side View	Description
	<p>Use Wifi stick for remote software update. Please contact Solplanet after-sales service department to implement specific operations.</p>

4.3 Basic system solution

The photovoltaic energy storage power generation system is composed of the following parts.

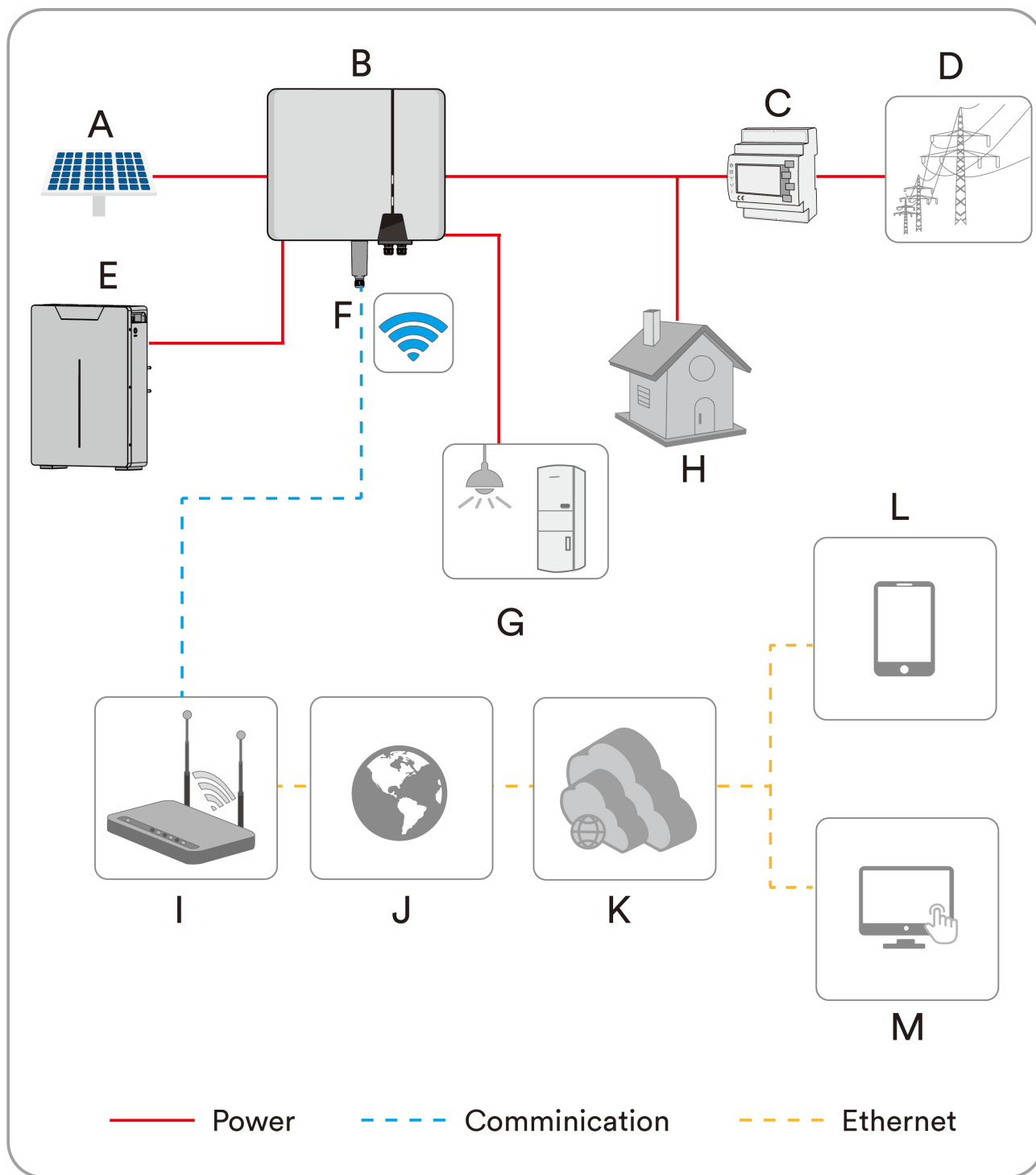

5 Mounting

5.1 Requirements for mounting

5.1.1 Requirements for Installation Location

DANGER

Danger to life due to fire or explosion !

Despite careful construction, electrical devices can cause fires. This can result in death or serious injury.

- Do not mount the product in areas containing highly flammable materials or gases.
- Do not mount the inverter in areas where there is a risk of explosion.
- A solid support surface must be available (e.g., concrete or masonry).
- The mounting location must be inaccessible to children.
- The installation location must be suitable for the weight and dimensions of the BESS.
- Keep away from conductive (metal) dust.
- Keep away from water sources, heat sources and inflammable and explosive articles.
- The installation location must not be close to fire.
- The product should be mounted such that the LED indicators can be read without difficulty.
- The circuit breaker of the BESS must always be freely accessible.
- The altitude of the installation location should be less than 3000 m.
- The charging temperature should be between -5°C ~ $+55^{\circ}\text{C}$. The discharging temperature should be between -15°C ~ $+55^{\circ}\text{C}$.
- The ambient humidity should be 5~95% RH, noncondensing.
- The mounting location must not be permanently exposed to direct sunlight . If the product is exposed to direct sunlight, the exterior components may age prematurely and overheating might occur. When becoming too hot, the BESS reduces its power output to avoid overheating, and will lead to reduced lifetime.

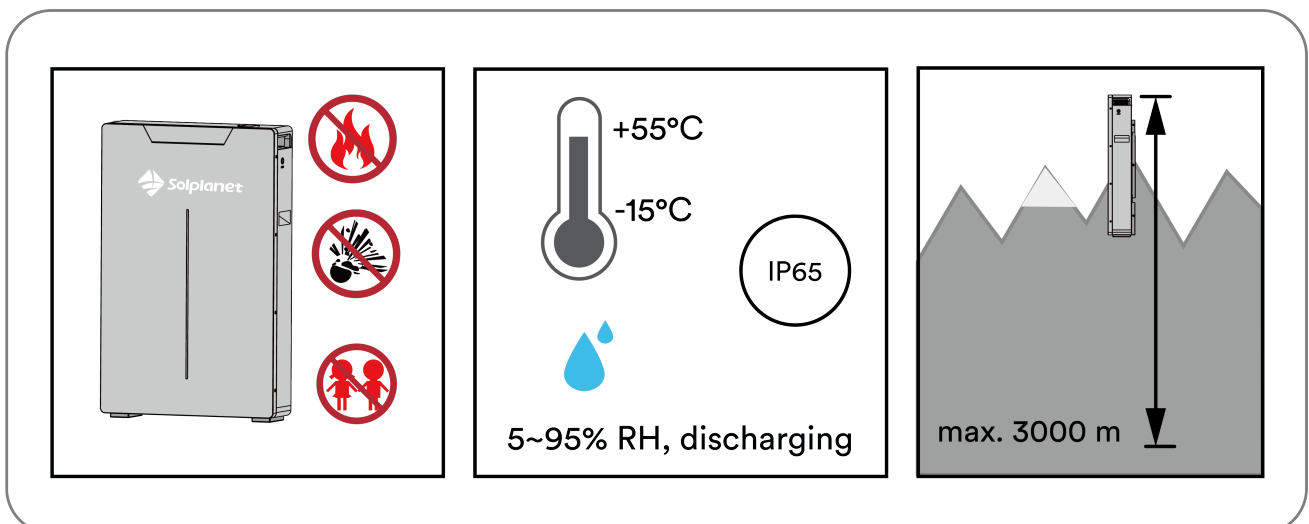

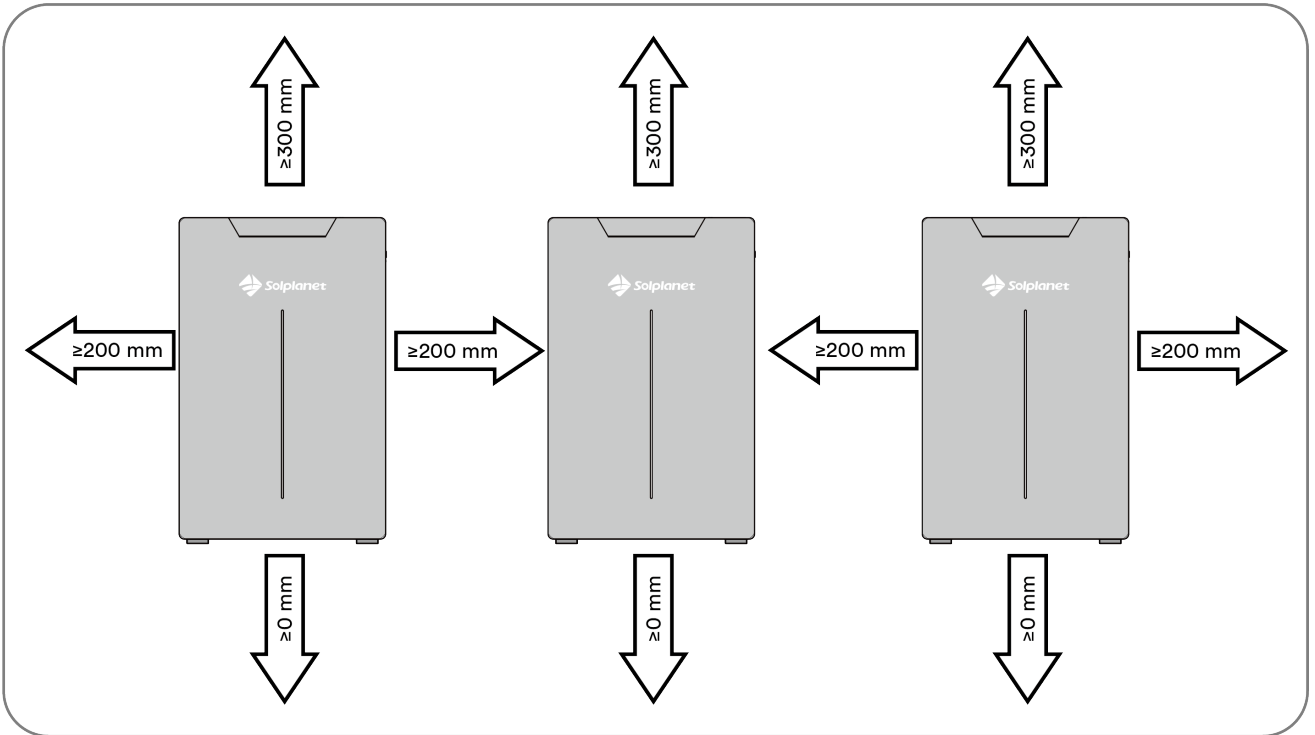
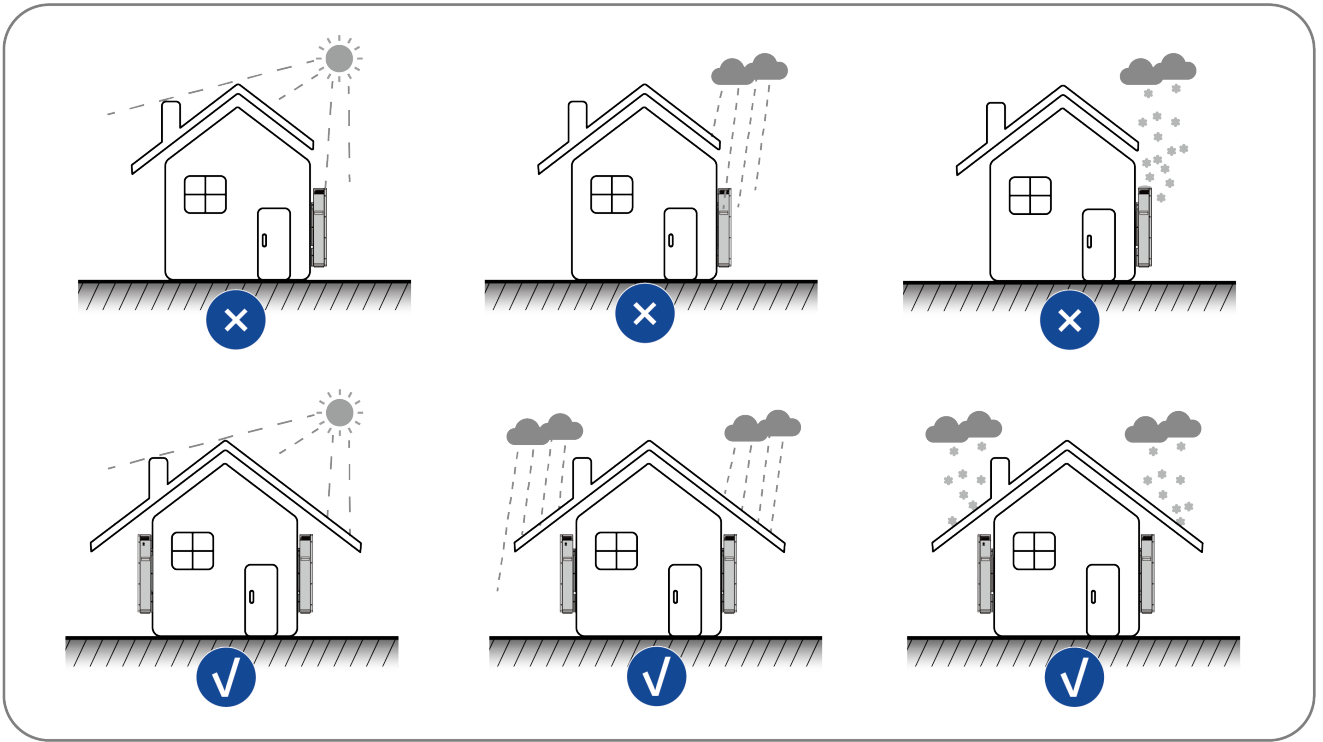

5.1.2 Tools

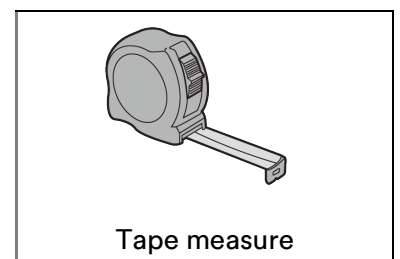
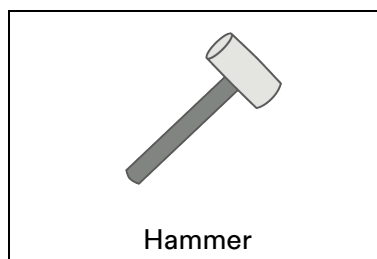
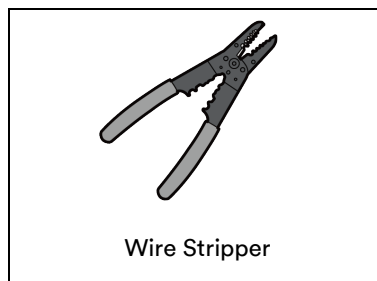
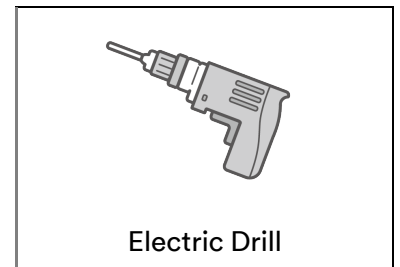
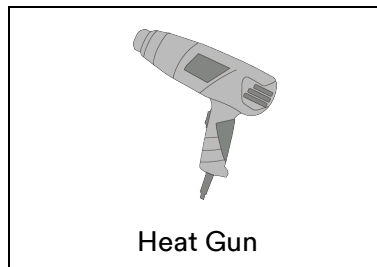
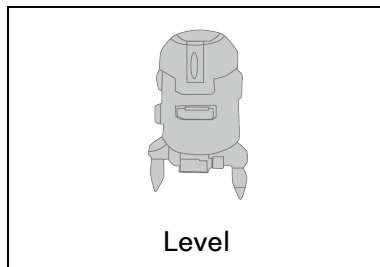
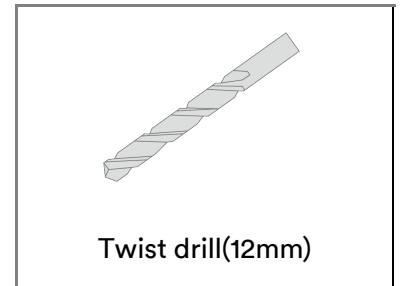
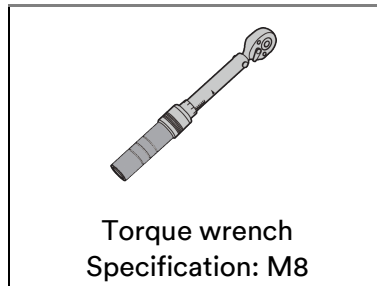
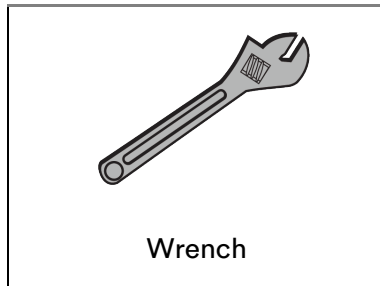
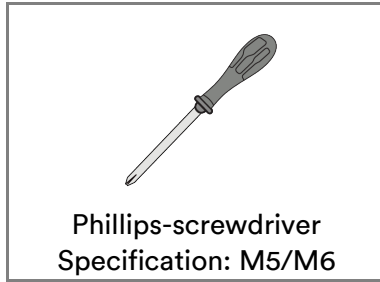

5.1.3 Safety gear

Wear the following safety gear when working on the BESS. Adhere to local occupational health and safety standards.

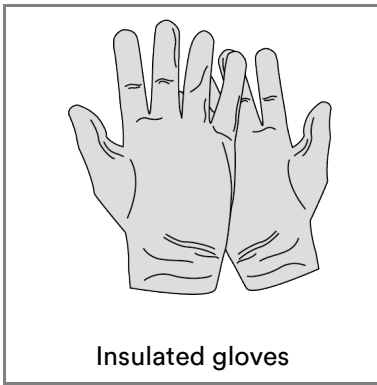

5.2 Mounting

Step 1: Measure the mounting space (position a cardboard the same size as the battery). Mark the fixed position with the "Mounting Locating Plate(H)".

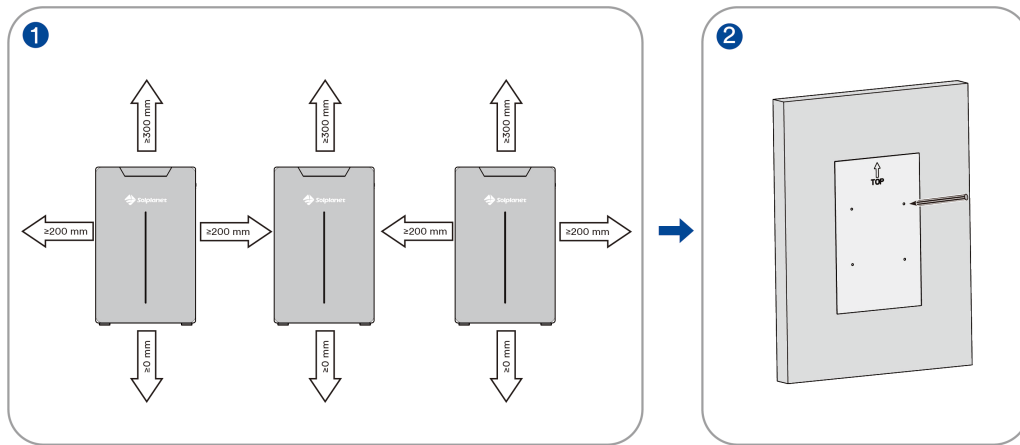

Step 2: Use an impact electric drill to drill holes in the concrete or stone (fireproof) wall, the drilling depth is between 80mm and 85mm: The drill diameter is 12 mm.

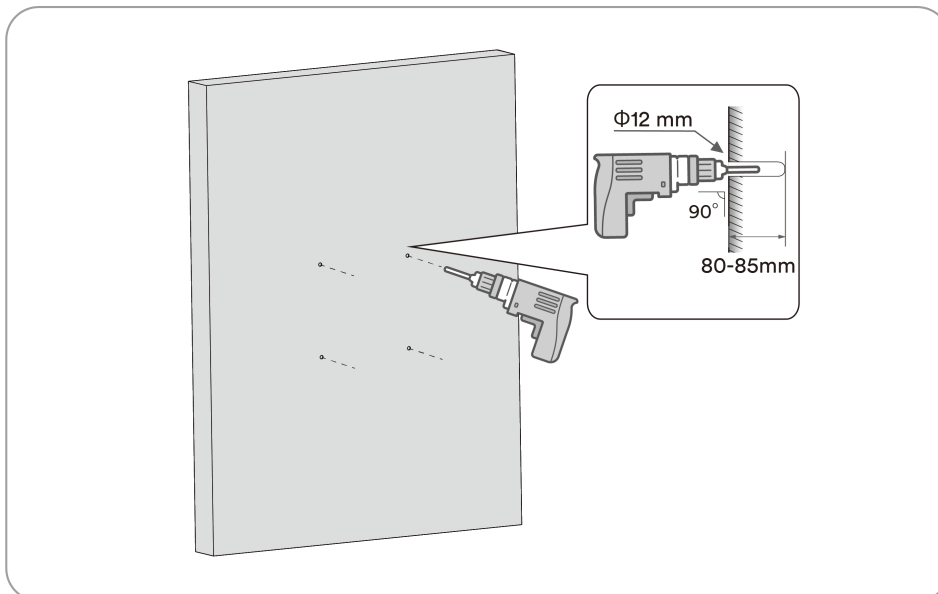

Step 3: ① Tighten the "Expansion Bolt(F)" slightly and put it into the hole. Knock the expansion bolt with a rubber hammer until all the expansion plugs enter into the hole. ② Screw out the bolts and remove the spring washer and flat washer.

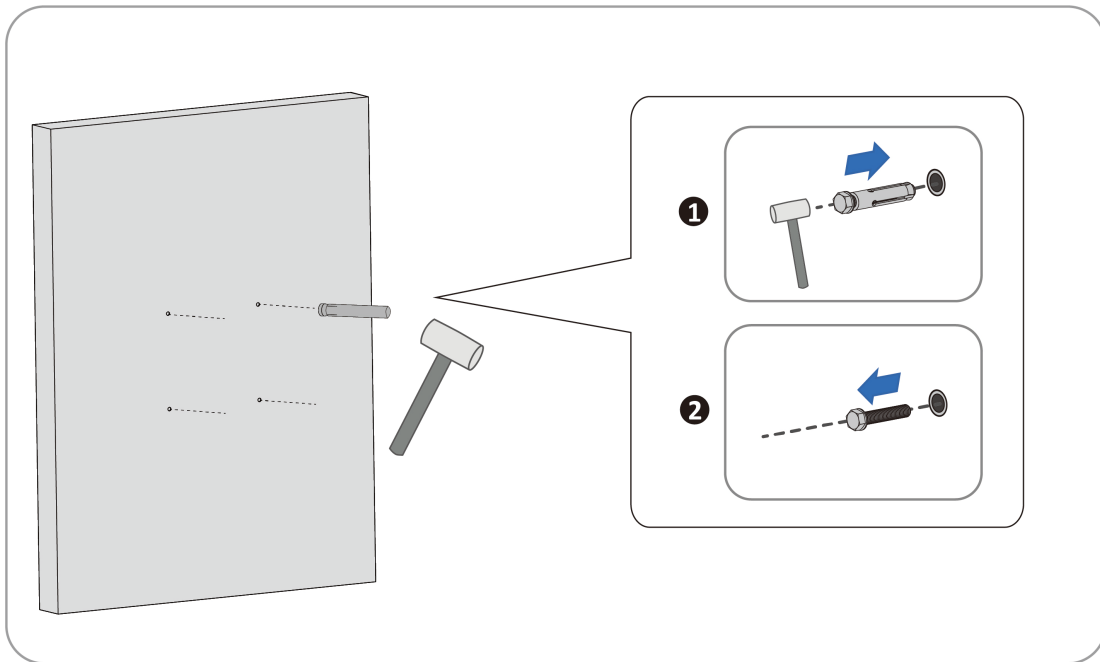

Step 4: Fix the "Back Plate (E)" to the wall.

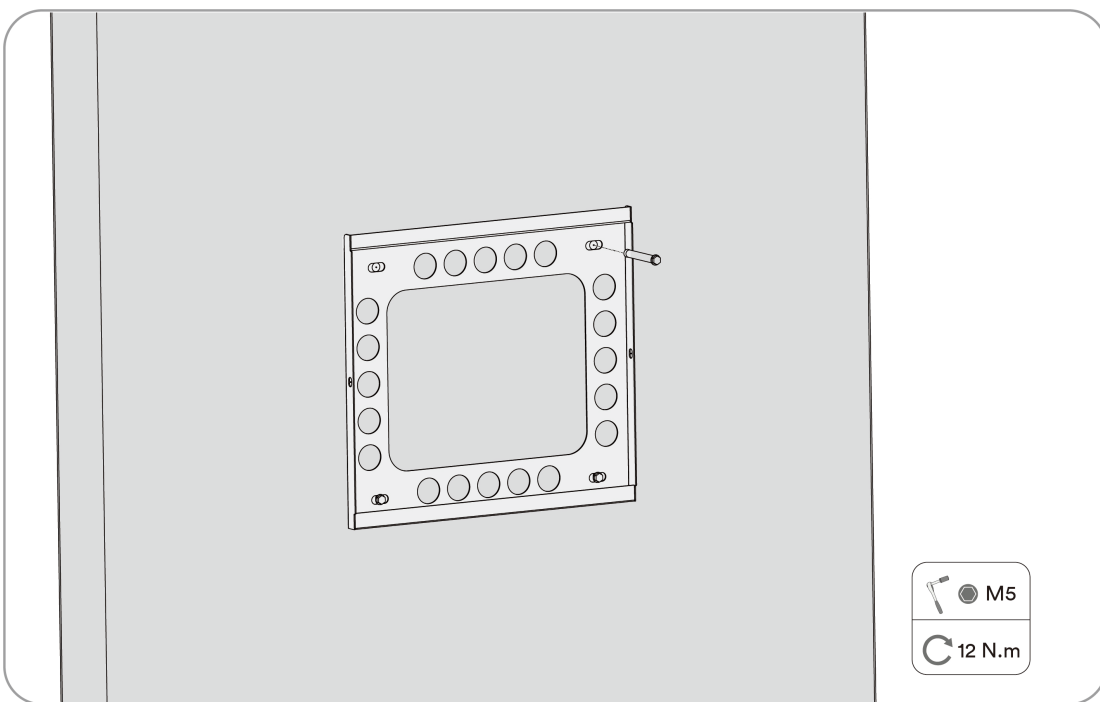

Step 5: Hang the battery on the bracket according to the picture below.

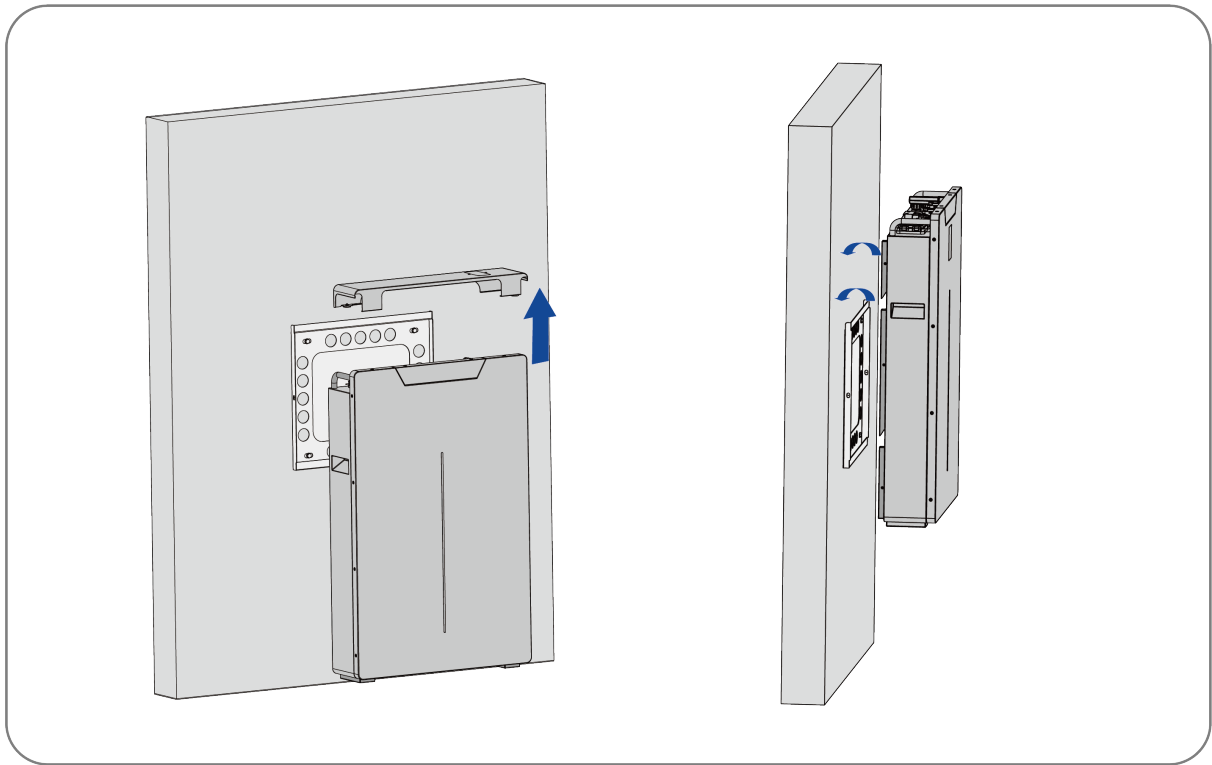

Step 6: Secure the PACK from the side using " Screws(G)".

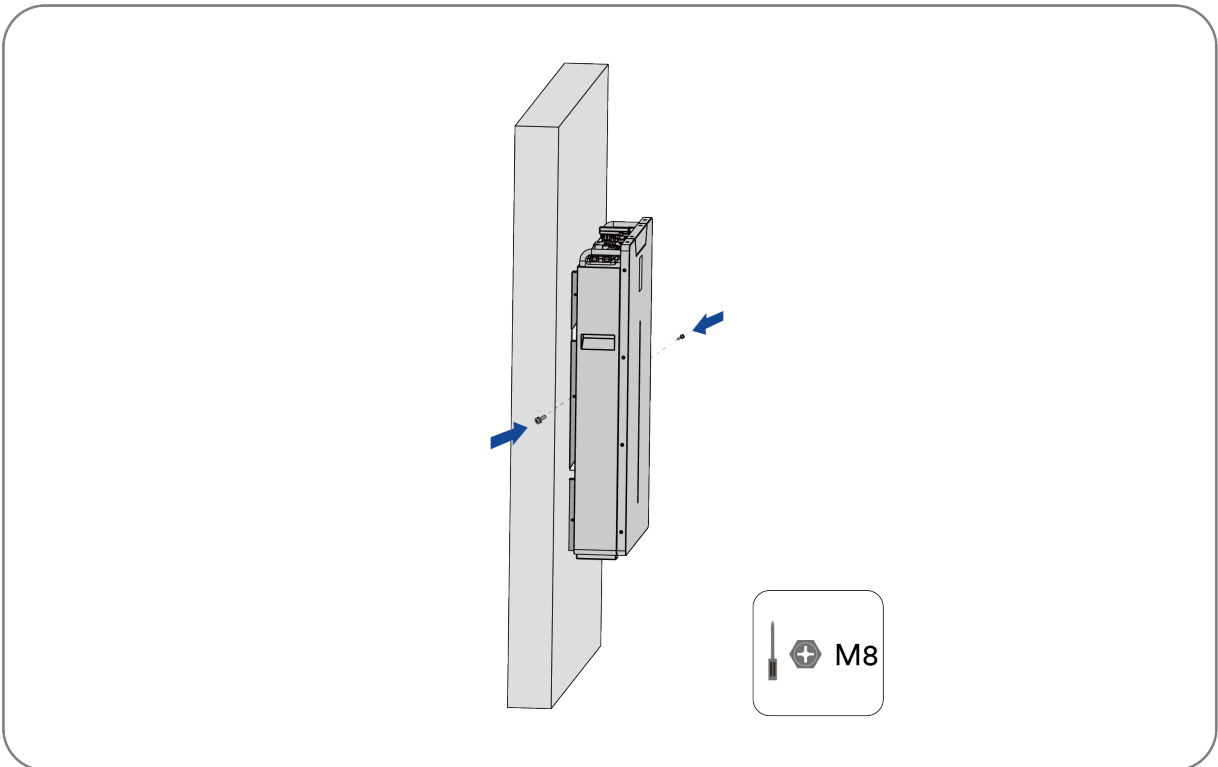



6 Electrical connection

6.1 Requirements for the Electrical connection

6.1.1 Power Cable

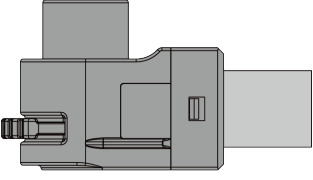
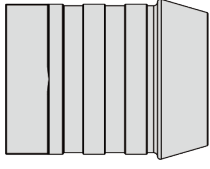
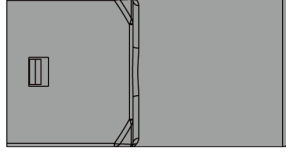
Material List (plug components may be purchased separately from supplier).

 <p>Plug sub assembly</p>	 <p>Cable sealing ring</p>	 <p>Plug protection cover</p>
--	---	--

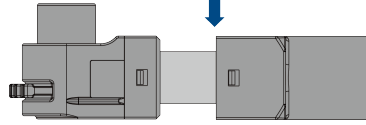
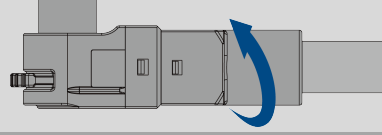
Procedure	Schematic picture
1.Route the cable through the isolation cable sealing ring and Plug protection cover.	
2.Remove 13mm of insulation at end of cable.	
3.The red plug is used for the positive, and the black is for the negative power cable. The end of the cable is crimped at the terminal using a crimping clamp.	
4.Tighten the isolation cap and plug contact.	
5.Connect the positive and negative plug into the “+” and “-” Port of the BESS and tighten.	
6.Use isolation cap for unused DC plug.	

6.1.2 Communication Cable

Battery to Battery Communication Cable.

Pin definition as below, alternatively a standard straight CAT 5 Ethernet cable can be used.

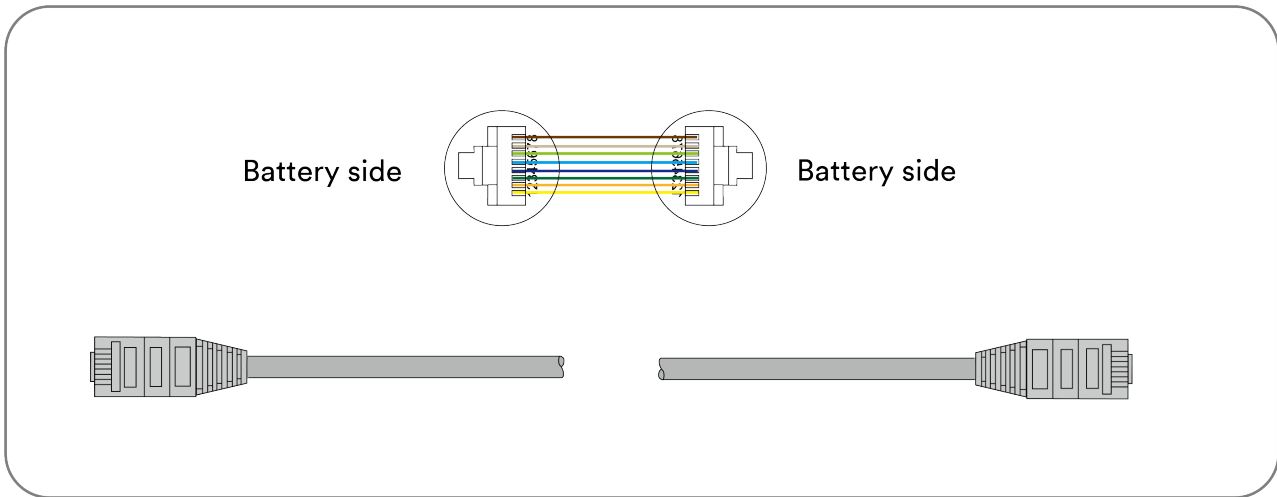

Battery to Inverter Communication Cable

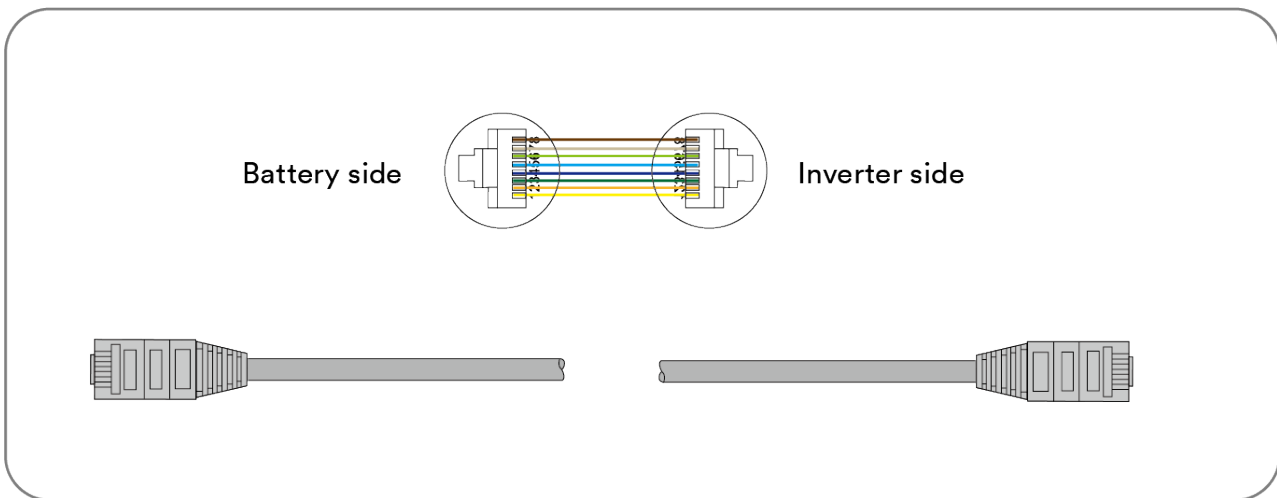

6.1.3 Install an isolation device

Install an isolation device (i.e., a circuit breaker) between the inverter and the battery system to run both positive and negative conductor overcurrent protection. The steps for installing isolation devices (i.e., circuit breakers) are as follows:

1. Use E25-16 terminals to connect the wiring harness to the isolation device.
2. Insert the wiring harness terminal into the connection port of the isolation device and distinguish the positive and negative terminals of the isolation device (see the isolation device specifications for details).
3. Tighten the wiring harness terminal with screws to secure it.



During installation, please turn off the battery power switch and check whether the power is off. The cable from the circuit breaker to the inverter is provided by the installation personnel. (Please refer to the Product Packaging List for cable specifications).

6.2 Single Unit Connection

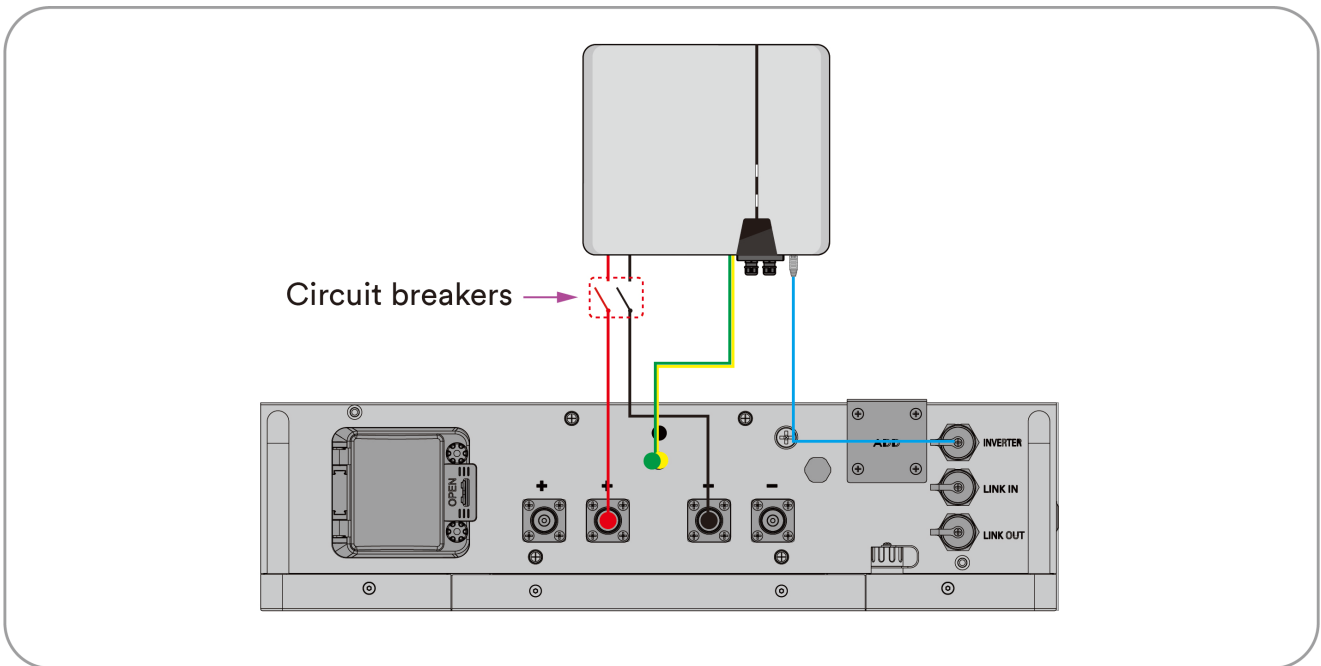

NOTICE

Before electrical connection, ensure that the circuit breaker/power switch of the battery and all switches connected to the energy storage are in the OFF state. Otherwise, electric shock may occur.

1. The rated output power of the cable connection is 6 kW; SOC>70% The output power is 8 kW.
2. Install circuit breakers based on local regulations.

6.3 Ground Connection

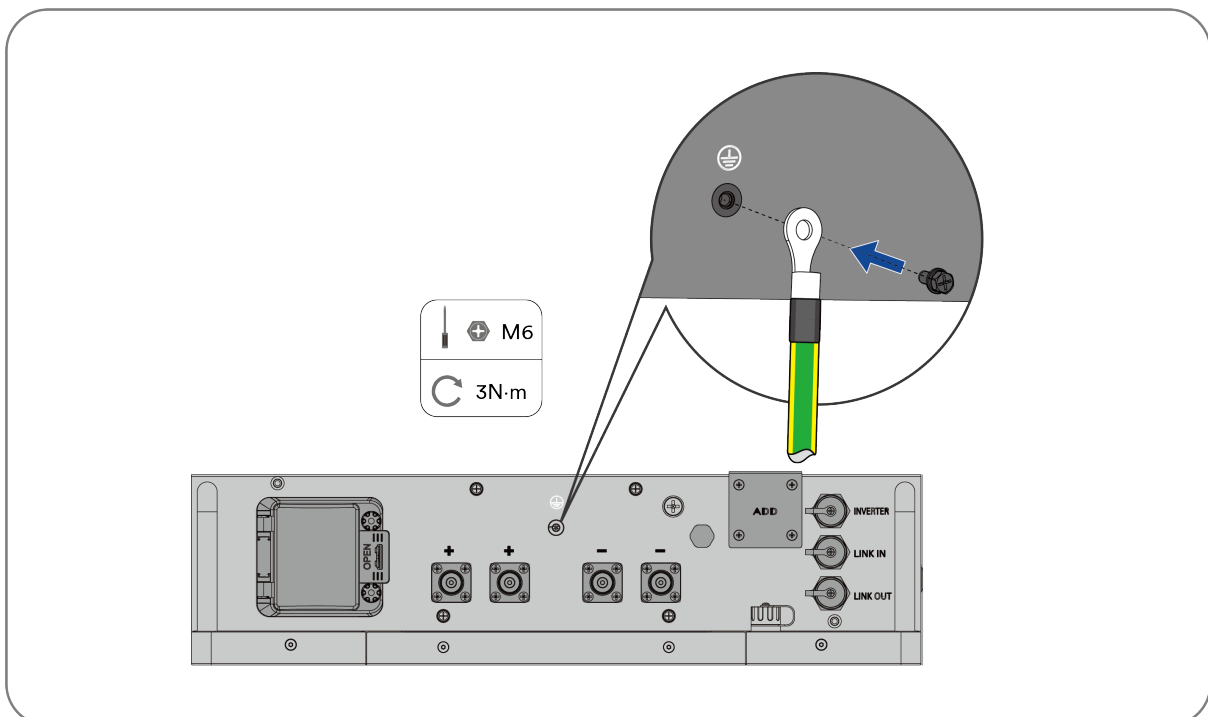

6.4 Communication Connection

Step 1: Route the communications cable through the "RJ45 Water-proof Wiring Terminal(l)".

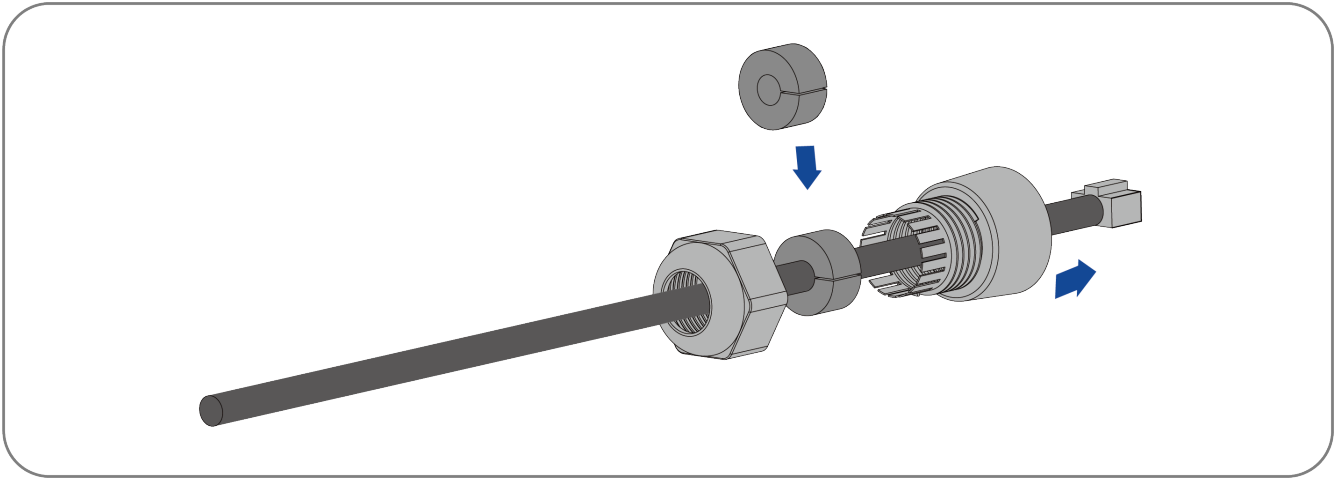

Step 2: Connect the communications cable to the RJ45 port (labelled "Inverter").

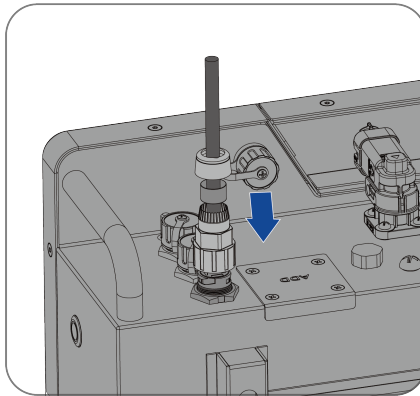

Step 3: Tighten the RJ45 cable cover.

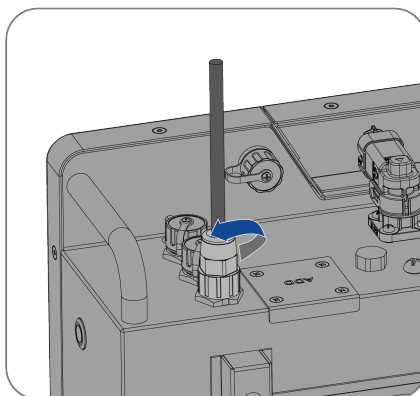

Step 4: Connect the other end of the communication cable to the inverter.

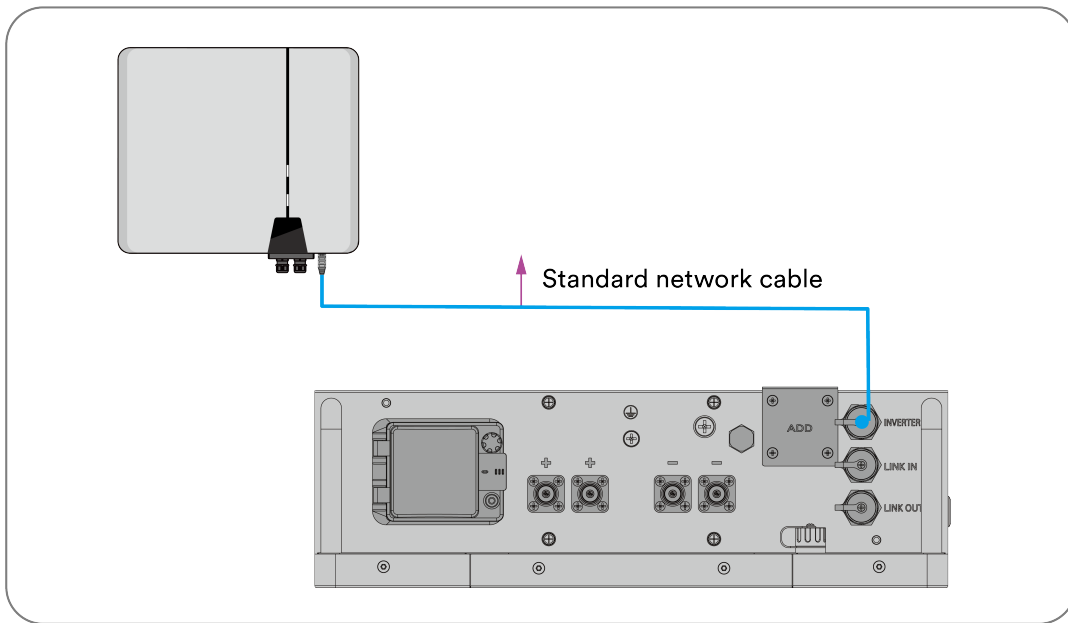

6.5 Power Cable Connection

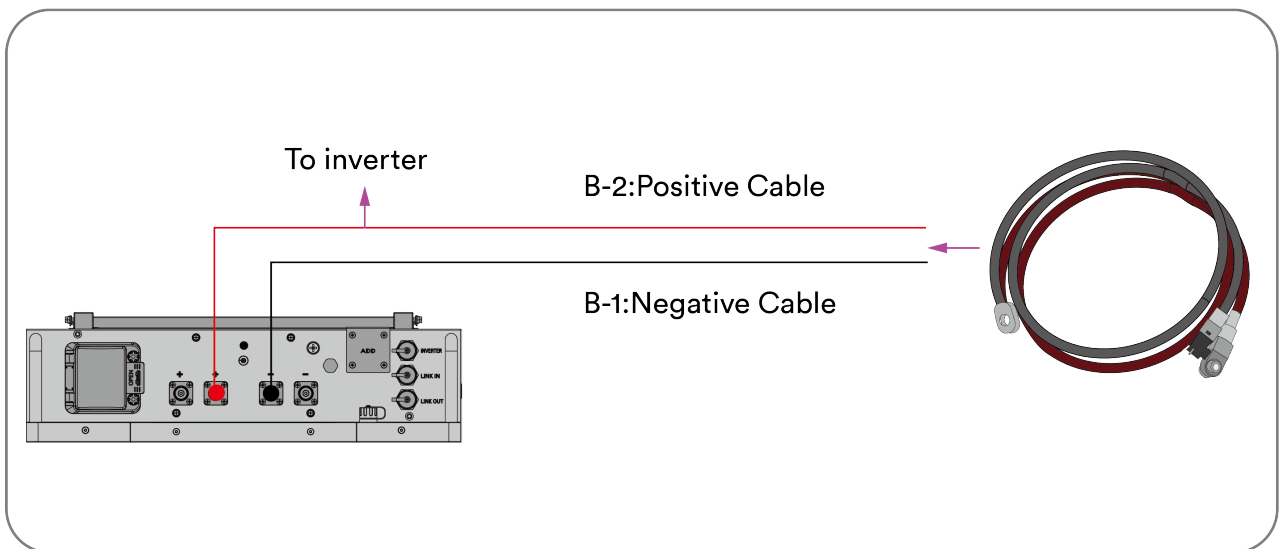





6.6 Turn On Battery

Step 1: Turn on the DC isolator on the BESS while the power switch is off.

Step 2: Press the “Power Switch” to turn on battery. After five seconds, the blue LED flashes to indicate normal operation.

Step 3: Cover with the front cover after checking.

State	Standby	Charge	Discharge	Failure
Light				
Remarks	LED illuminates for 0.25 S / LED turns off for 0.75 S	LED illuminates for 0.5 S / LED turns off for 0.5 S	Permanently illuminated	Continuous blinking
When the battery starts up, the red and blue lights alternately blink, indicating that the battery self-test is normal				

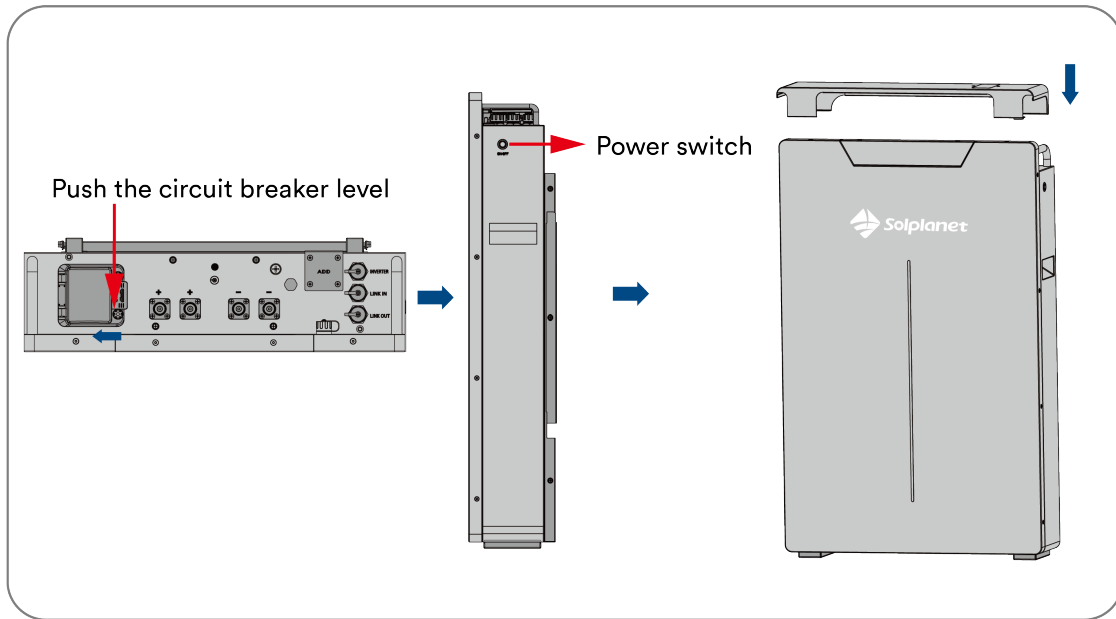

6.7 Shutdown Battery

Step 1: Press the “Power Switch” to shutdown battery.

Step 2: Turn off the DC isolator while the power switch is off.

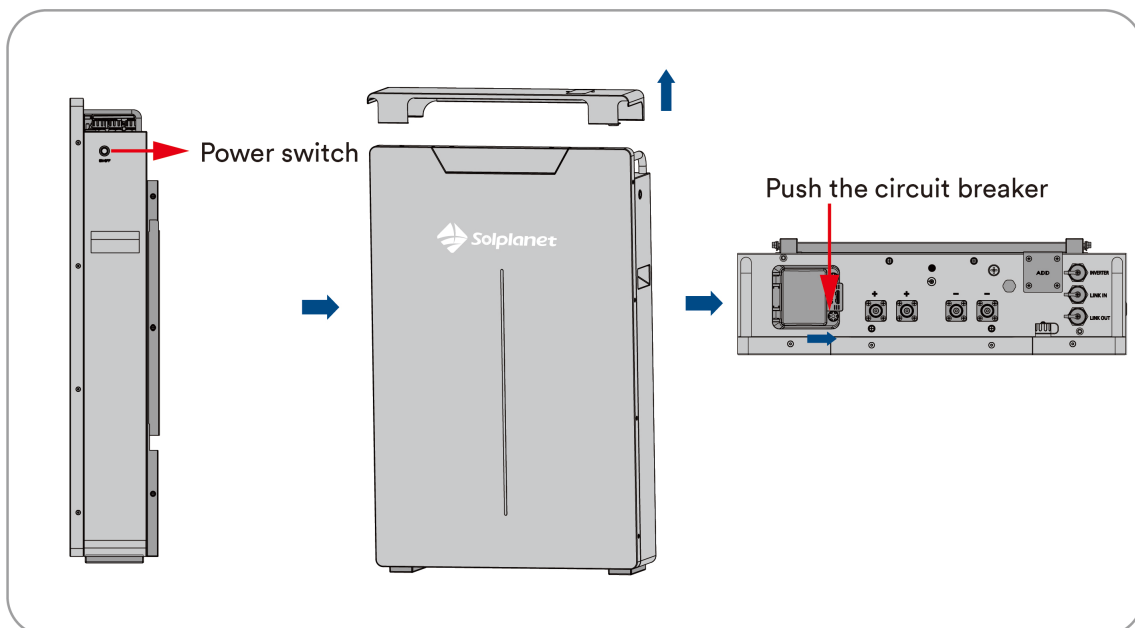

6.8 Multi-Unit Connection with Bus-Bars (3-unit example)

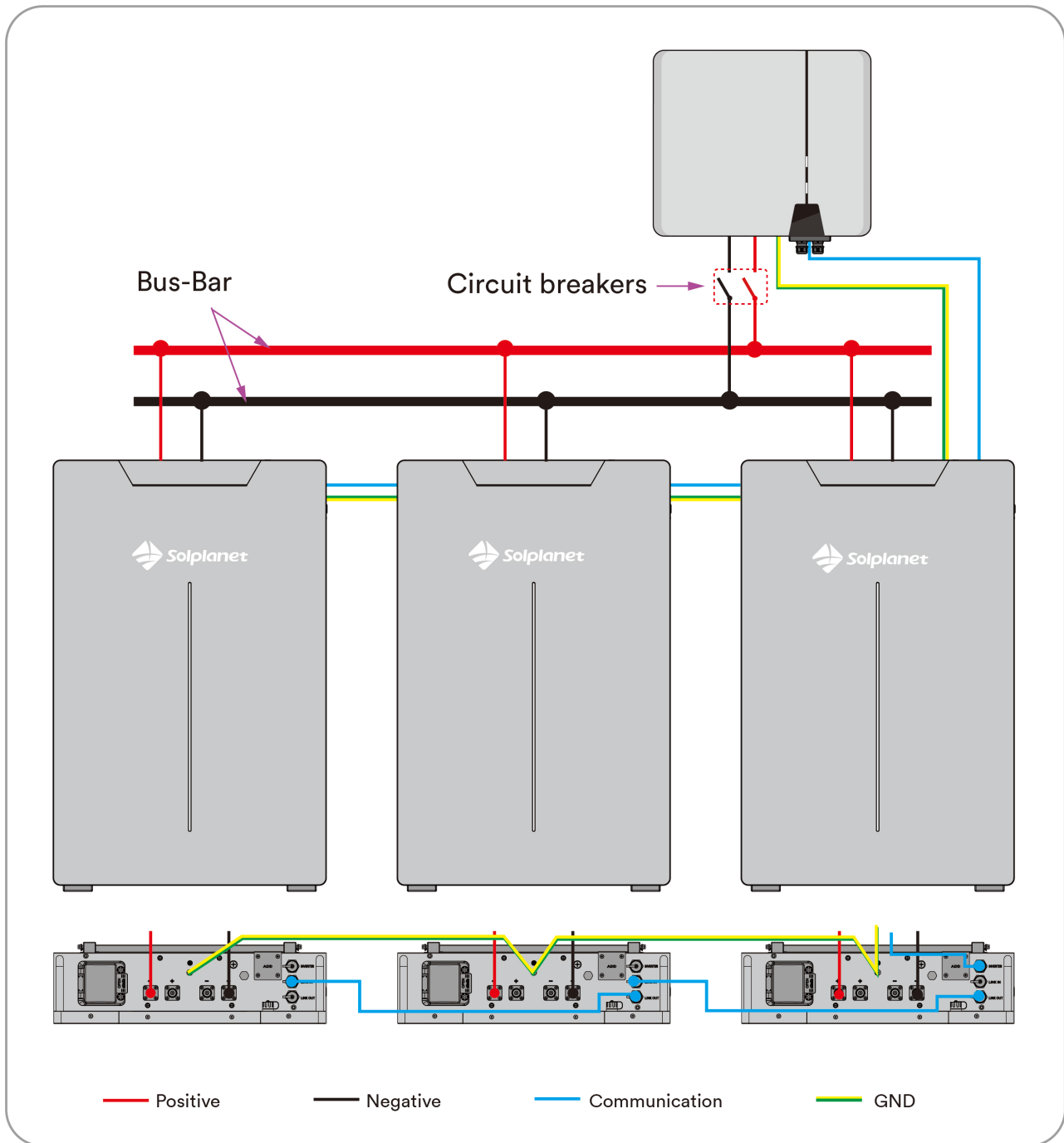

Step 1: The method of cable connection with a bus-bar will output a power of $3 \times 6 \text{ kW} = 18 \text{ kW}$.

Step 2: Max. number of parallel units: 16. Note that the max. recommended charge and discharge power is 96 kW continuous and 130 kW peak respectively.

Step 3: Install circuit breakers based on local regulations.

You can also use a $40 \times 4 \text{ mm}^2$ copper bar with a flow capacity of 500A as the bus bar.

6.9 Multi-Unit Connection without Bus-Bars (3-unit example)

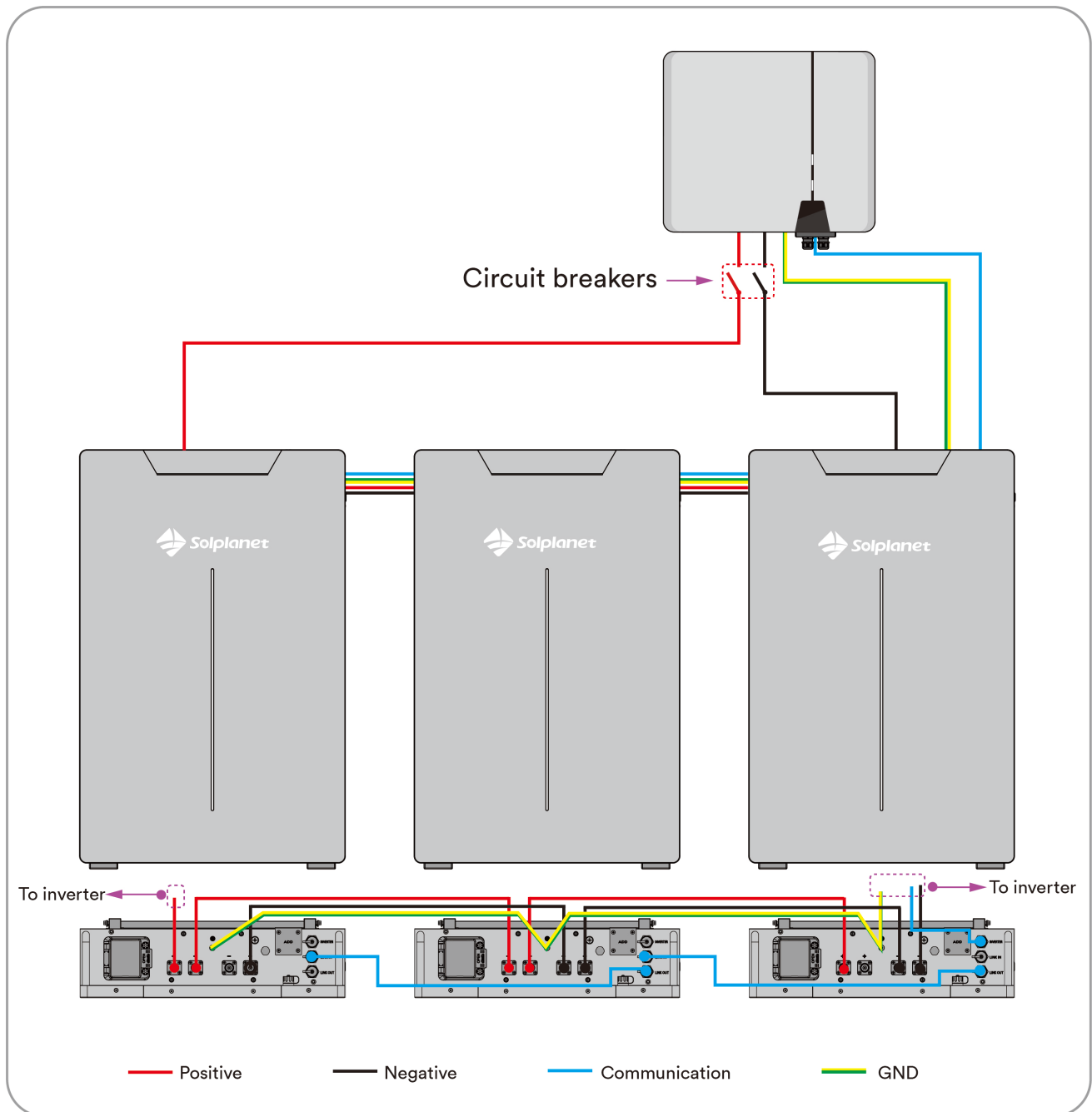

Step 1: This wiring method will allow a max. power output of 6 kW continuous, limited by the wiring and connectors. Ensure the connected inverter does not exceed 6 kW/120 A continuous during both charge and discharge.

Step 2: Install circuit breakers based on local regulations.

6.9.1 Ground Connection

Please follow step 6.2.

6.9.2 Communication Connection

Please follow step 6.3.

6.9.3 Power Cable Connection

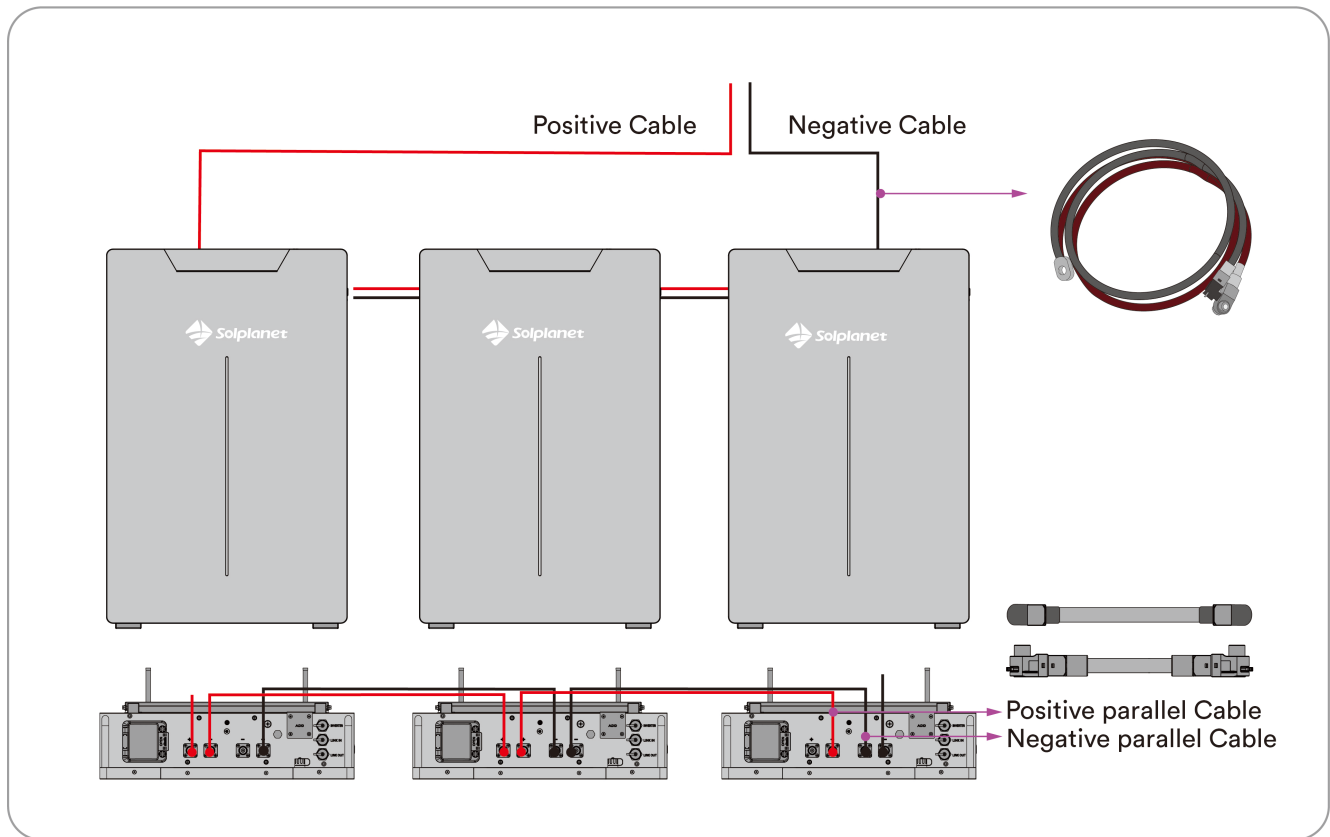

Parallel cable needs to be purchased extra.

6.9.4 Turn On Battery Bank

Please follow step 6.6. Make sure all isolators are turned on before pressing the power switches on all batteries.

7 Commissioning

7.1 Inspection before commissioning

Check the following items before commissioning the BESS:

- Ensure inverter is compatible with the battery. The official compatibility list can be found at www.solplanet.net
- Ensure the inverter is correctly mounted as per Solplanet's guidelines, please refer to the inverter user manual
- Ensure the battery is properly installed and secured in accordance with this user manual.
- Ensure the isolator between the battery system and the inverter is off.
- Ensure the communication cables and DC cables are correctly and securely connected.
- Ensure the ground terminal on the BESS is grounded.
- Ensure the DC power cables have been installed with the correct polarity.

7.2 Commissioning procedure



The battery can operate together with Solplanet inverters as default. Monitoring of the battery status is available via the Solplanet App when installed with a Solplanet inverter. If the battery operate together with the other inverters, please contact Solplanet service.

If all the items mentioned above have been met, then proceed as follows to commission and start-up the battery for the first time:

Step 1: Turn the battery isolator while the power switch is off.

Step 2: Turn on Power Switch to start battery. After five seconds:

- ① If the Power Switch LED blinks blue, it means that the battery enters into working modes. Proceed to step 3.
- ② If the Power Switch LED blinks red or is permanently illuminated red, it means that a battery alarm has occurred after the system self-check, please stop the commissioning procedure and call the local Solplanet service support for assistance.

Step 3: Start inverter according to the inverter start-up procedure.

Step 4: Commission the inverter according to the inverter commissioning procedure using the Solplanet App.

Step 5: Read the battery status information using the Solplanet App and confirm that the BESS is communicating with the inverter.

8 Decommissioning the product

Procedure:

Step 1: Switch off the inverter by first turning off the AC circuit breaker downstream of the AC output of the inverter and second by turning off the inverter DC switch.

Step 2: Switch off the BESS. Ensure that the Power Switch LED is OFF.

Step 3: Switch off the any external DC switches between the inverter and the BESS if there are any.

Step 4: Remove all cables from the BESS.

Step 5: If the battery system is to be stored or shipped, pack the system using the original packaging or packaging that is suitable for the weight and dimensions of the system. Dispose of the battery system in accordance with the locally applicable battery disposal regulations.

9 Technical data

Key Item	Specification	Remark
Rated Capacity	200 Ah	
Rated Voltage	51.2 Vdc	
Working Voltage Range	44.8-58.4 V	
Rated Energy	10.24 kWh	
Max. Parallel Quantity	Max.16 Sets In Parallel, 163.84 kWh	
Rated Charging Current	0.6 C, 120 A	
Max. Charging Continuous Current	0.6 C, 120 A	
Rated Discharge Current	0.6 C, 120 A	
Max. Discharge Continuous Current	0.6 C, 120 A	
Battery Max. Charge/Discharge Power	6.14 kW / 6.14 kW	
Peak Discharge Current / Power	160 A / 8.19 kW, 1 min	
Available SOC Range	0 % ~ 100 %	90 % DOD is recommended.
SOC during transportation	50 %	
Dimensions [W*D*H]	Width: 550 (±5) mm / 21.65 in, Depth: 165 (±5) mm / 6.50 in, Height: 867 (±5) mm / 31.21 in	
Weight	~94 kg	
Operating Temperature ¹	Charging Temperature: -5 °C ~ 55 °C Discharge Temperature: -15 °C ~ 55 °C	
Storage Temperature ²	-10 °C ~ 50 °C	
Working Humidity	5~95 %RH (Non-Condensing)	
Altitude ³	≤2000 m	
Communication	CAN, RS485, Dry Contact, WiFi	WiFi Stick Option
Certificate	TUV, IEC 62619, IEC62040, IEC61000, UN38.3	
Designed Cycle Life	6000 Cycles	0.5 C/80 % DOD/80 % SOH/1 Cycle Per Day (25 °C±2 °C)
IP Rating	IP65	
Cooling	Natural Cooling	
Environment protection standard	RoHS, REACH	

1. Recommended operating temperature: 10 ~ 30°C.

2. Recommended Storage temperature: 10 ~ 30°C.

3. Recommended working height is less than 2000 m, and the maximum working height is 3000 m.

10 Handling Precautions and Guidelines for Product

These Handling Precautions and Guidelines for Rechargeable Battery System (“Handling Precautions and Guidelines”) shall only apply to the packs manufactured by AISWEI New Energy Technology (Yangzhong) Co., Ltd (hereinafter referred to as “AISWEI”). Customer shall strictly follow these Handling Precautions and Guidelines, and shall alert its customers, contract manufacturers, agents, distributors, service providers and end users of the risks of the packs and shall ensure that Customer’s obligations as specified in the Document as well as the Handling Precautions and Guidelines are, through a printed label on host device, or through Customer’s Quick Installation Guide, or a help file or Customer’s Internet website, contractually imposed on Customer’s own customers and distributors, and by them further down to the end users so that the entire chain is committed to the above obligations and so that the products are properly handled, operated, transported, used and maintained.

Statement (1):

Customer is requested to contact AISWEI in advance, if and when the customer needs other applications or operating conditions than those described in this Document. Additional experimentation may be required to verify performance and safety under such conditions

Statement (2):

AISWEI will take no responsibility for any accident or liabilities in the event the Product is used for applications or under conditions other than those described in this Document.

- Use Product under specified charge/discharge conditions.
- Do not immerse in water.
- Do not heat.
- Do not attempt to crush, drop or penetrate the pack.
- Do not attempt to have any modification/.
- Leave Product in cool places.
- Stop using Product with any colour change or mechanical damage detected during assembling, charging, normal operation and storage.
- In case of leakage or smells, track to thermal source, remove the thermal source and clean with water.
- Do not place or leave the pack and equipment in the reach of children so that they are not able to swallow or mistreat the product. In case of ingestion, consult with a doctor immediately.
- Keep leaked electrolyte away from eyes or skin. In case of leakage contact with eyes or skin, immediately clean with water and seek help from a doctor. Serious damages can be caused due to delayed treatment.
- Do not put the pack into a fire. Do not use it or leave it in a place near fire, heaters, or high temperature sources. The heat can melt pack insulator and damage safety vent, resulting in overheat, explosion or fire of the pack .
- Do not submerge the product in water or wet the product. If the protective devices are damaged, abnormal charging current and voltage may cause a chemical reaction within the product, which may result in overheat, explosion and even fire of the pack.
- Do not connect positive (+) and negative (-) terminals of the pack reversely.
- Do not short circuit. Do not contact the pack terminals (+ and -) directly with a wire or any metal (like a metal necklace or a hairpin). Otherwise, the pack is short circuited and generates excessive current, which may result in overheat, explosion, or fire of the pack.
- Do not throw or drop the pack. Strong impact may damage the protective devices and an abnormal chemical reaction might occur during charge, resulting in overheat, explosion, or fire of the pack.
- Do not drive a nail in, hit with a hammer, or stamp on the pack. Otherwise, the pack may be deformed and short circuited, resulting in overheat, explosion, or fire of the pack.
- Do not solder the pack directly. Heat applied during soldering may damage the insulator of the safety vent and mechanism, resulting in overheat, explosion, or fire of the pack.
- Do not disassemble or alter the pack. The pack employs a safety mechanism and a protection device in order to avoid any danger. If they are damaged, the pack might overheat, explode or catch a fire.
- Do not put the pack in a microwave oven or a pressure cooker. Sudden heat may damage the sealing of the pack and may cause overheat, explosion, or fire of the pack.

- Do not leave the pack in a charger or equipment if it generates an odour and/or heat, changes colour and /or shape, leaks electrolyte, or encounters any other abnormality. In such a case, immediately take the pack out of the charger or equipment and keep it away from fire. Otherwise, the pack might overheat, explode, or catch a fire.
- Stop charging or using the battery after battery reaches its lifetime, otherwise, as the PACK might cause heat generation, explosion, or fire.
- Do not use the pack beyond specified conditions. Otherwise, the pack might encounter overheat, damage, or performance deterioration.
- Read the instructions regarding the installation and operation so as to avoid damages due to incorrect operations.
- The pack may have insufficient power capacity after long storage.
- Knockoff or counterfeit battery.
- Any inconsistency between serial number, model number, and product code.

11 Maintenance

To ensure the long-term running of the energy storage system (hereinafter referred to as “the system”), you are advised to perform the following maintenance operations:

Check content	Maintenance method	Maintenance cycle
System cleaning	<ul style="list-style-type: none"> Check whether the appearance of the system is damaged or deformed. Clean the system. 	Once every six months to once a year.
System running state	<ul style="list-style-type: none"> Check whether there is abnormal sound during the operation of the system. Check whether indicator LED's work normally. Check whether the system parameters are normal. Update software. 	Once every six months.
Electrical connection	<ul style="list-style-type: none"> Check whether the cable connections are loose. Check whether the cables are discolored. Check whether the cable is damaged, especially whether there is a cut mark on the surface of the cable in contact with metal surfaces. 	Half a year after the first commissioning, and once every half a year to a year thereafter.
Ground reliability	Check whether the ground cable is grounded reliably.	Half a year after the first commissioning, and once every half a year to a year thereafter.

12 Recycling and disposal

Dispose of the packaging and replaced parts according to the rules applicable in the country where the device is installed.

Do not dispose the Solplanet BESS with normal domestic waste.



Do not dispose of the product together with the household waste but in accordance with the disposal regulations for electronic waste applicable at the installation site.

13 EU declaration of conformity

Within the scope of the EU directives

- Radio Equipment Directive 2014/53/EU (L 153/62-106. May 22. 2014) (RED)
- Restriction of the use of certain hazardous substances 2011/65/EU (L 174/88, June 8, 2011) and 2015/863/EU (L 137/10, March 31,2015) (RoHS)



AISWEI New Energy Technology (Yangzhong) Co., Ltd. confirms herewith that the products described in this manual are in compliance with the fundamental requirements and other relevant provisions of the above mentioned directives.

The entire EU Declaration of Conformity can be found at www.solplanet.net.

14 Service and warranty

If you have any technical problems concerning our products, please contact Solplanet service. We require the following information in order to provide you with the necessary assistance:

- Ai-LB Pro battery energy storage system type
- Ai-LB Pro battery energy storage system serial number
- Ai-LB Pro battery energy storage system battery type
- Type and number of connected PV modules
- Error code
- Mounting location
- Installation date
- Warranty card

The factory warranty card is enclosed with the package, please keep well the factory warranty card. Warranty terms and conditions can be downloaded at www.solplanet.net, if required. When the customer needs warranty service during the warranty period, the customer must provide a copy of the invoice, factory warranty card, and ensure the electrical label of the machine is legible. If these conditions are not met, Solplanet has the right to refuse to provide with the relevant warranty service.

15 Contact

EMEA

Service email: service.EMEA@solplanet.net

APAC

Service email: service.APAC@solplanet.net

LATAM

Service email: service.LATAM@solplanet.net

AISWEI Pty Ltd.

Hotline: +61 390 988 674

Add.: Level 40, 140 William Street, Melbourne VIC 3000, Australia

AISWEI B.V.

Hotline: +31 208 004 844 (Netherlands)

+48 134 926 109 (Poland)

Add.: Barbara Strozilaan 101,5e etage, kantoornummer 5.12,1083HN Amsterdam, the Netherlands

AISWEI New Energy Technology (Yangzhong) Co., Ltd.

Hotline: +86 400 801 9996

Add.: No.588 Gangxing Road, Yangzhong Jiangsu, China

<https://solplanet.net/contact-us/>

Scan QR code:



Android

Scan QR code:



iOS

