

User Manual

Mira-HV25

In order to prevent improper operation before use, please carefully read this manual.

Table of Contents

1. Introduction	1
2. Symbols	1
3. Safety	2
3.1 Handling	2
3.2 Installation	2
4. Response to Emergency Situations	2
5. Product Information	3
5.1 Battery Module Specifications	3
5.2 Mira-BMS Specifications	3
5.3 Battery System Specifications	4
6. Product Features	5
6.1 Battery System Features	5
7. Installation	8
7.1 Items in the package	8
7.2 Clearance	9
7.3 Tools	9
7.4 Installation Steps	10
7.5 Wiring Steps	12
7.6 System Start up	14
8. Commissioning	15
9. Exclusion	17
10. Troubleshooting and Maintenance	17
10.1 Maintenance	17
10.2 Troubleshooting	17

1. Introduction

The document describes the installation, commissioning, maintenance and troubleshooting of the following high voltage battery listed below.

Mira-HV25

Note: Mira-HV25 = 2.45kWh High Voltage

The battery chemistry of these products is Lithium Iron Phosphate. This manual is designed for qualified personnel only. The tasks described in this document should be performed by authorized and qualified technicians only.

After Installation the Installer must explain the user manual to the end user.

2. Symbols

	Caution, risk of electric shock.
	Do not place nor install near flammable or explosive materials.
	Install the product out of reach of children.
	Read the instruction manual before starting installation and operation.
	Do not dispose of the product with household wastes.
	Recyclable.
	Disconnect the equipment before carrying out maintenance or repair.
	Observe precautions for handling electrostatic discharge sensitive devices.
	Protective Class 1.
	Caution, risk of electric shock, energy storage timed discharge.

3. Safety

Any work on the Batteries should be handled by authorized technicians and hence it is understood that the technicians should familiarize themselves with the contents of this manual before any maintenance or installation is carried out on the system.

3.1 Handling

- Do not expose battery to open flame.
- Do not place the product under direct sunlight.
- Do not place the product near flammable materials. It may lead to fire or explosion in case of accident.
- Store in a cool and dry place with ample ventilation.
- Do not store the product near water sources.
- Store the product on a flat surface.
- Store the product out of reach of children and animals.
- Do not damage the unit by dropping, deforming, impacting, cutting or penetrating with a sharp object. It may cause leakage of electrolyte or fire.
- Do not touch any liquid spilled from the product. There is a risk of electric shock or damage to skin.
- Always handle the battery wearing the insulated gloves.
- Do not step on the product or place any foreign objects on it. This can result in damage.
- Do not charge or discharge damaged battery.
- Do not store the battery near water sources.

3.2 Installation

- Do not connect the Mira-HV25 to inverter conductors or Photo-Voltaic conductors. This will damage the battery and may result in explosion.
- After unpacking, please check the product for damages and missing parts.
- Make sure that the inverter and battery is completely turned off before commencing installation.
- Do not interchange the positive and negative terminals of the battery.
- Ensure that there is no short circuit of the terminals or with any external device.
- Do not exceed the battery voltage rating of the inverter.
- Do not connect the battery to any incompatible inverter.
- Do not connect different battery types together.
- Please ensure that all the batteries are grounded properly.
- Do not open the battery to repair or disassemble. Only Fox is allowed to carry out any such repairs.
- In case of fire, use only dry powder fire extinguisher. Liquid extinguishers should not be used.
- Install the batteries only inside approved Fox enclosure. Installing the battery anywhere outside is strictly forbidden.
- Do not install the battery near water sources or places where the battery can get wet.
- Install the battery away from children or pets.
- Do not use battery in high static environment where the protection device might be damaged.
- Do not install with other batteries or cells.
- Batteries with different color SN label cannot be mixed in one system.

4. Response to Emergency Situations

The batteries comprise of multiple batteries connected in series. It is designed to prevent hazards or failures. However, Fox cannot guarantee their absolute safety.

Under exposure to the internal materials of the battery the following recommendations should be carried out by the user.

- If there has been inhalation, please leave the contaminated area immediately and seek medical attention.
- If there has been contact with eyes, rinse the eyes with running water for 15 minutes and seek medical attention immediately.
- If there has been contact with the skin, wash the contacted area with soap thoroughly and seek medical attention immediately.
- If there has been ingestion, induce vomiting and seek medical attention.

Fire Situation

In situations where the battery is on fire, if it is safe to do so, disconnect the battery pack by turning of the circuit breaker to shut off the power to the system. Use FM-200 or Co2 fire extinguisher for the battery and an ABC fire extinguisher for the other parts of the system.

Under any fire situation, please evacuate the people from the building immediately before trying to extinguish it.

Water Situation

The battery modules are not water resistant. Hence care should be taken not to get it wet. If you find the battery completely or partially submerged in water do not try to open. Contact an authorized personnel or Fox for further instructions.

5. Product Information

1. Mira-HV25 is a battery module, it needs to be used with Mira-BMS controller;
2. Mira-BMS is the controller of the whole system, so each system must have one Mira-BMS;
3. Our system consists of at least 2 Mira-HV25 + 1 Mira-BMS and up to 8 Mira-HV25 + 1 Mira-BMS.

5.1 Battery Module Specifications

Specifications for Mira-HV25	
Battery module	Mira-HV25
Nominal capacity (kWh)	2.45
Maximum charge voltage (V)	58.8
Discharge cut voltage (V)	46.4
Max. charge/discharge current (A)	48A/48A
Operating temperature (°C)	-10 ~ 55
Storage temperature (°C)	-10 ~35
Charge/Discharge efficiency (%)	>95
Ingress protection	IP21
Protective class	I
Cycle life	>4000 @25°C @80% SOH
Available SOC range	3%~100%
Weight (kg)	30.2±1 kg
Dimensions (L*W*H) (mm)	440*420*122

5.2 Mira-BMS Specifications

Specifications for Mira-BMS	
Model NO.	Mira-BMS
Operating voltage range(V)	86.4-500VDC
Max. charge/discharge current (A)	48A/48A
Total voltage measurement accuracy	±1.0%FSR
Total voltage measurement channel	4
Current measurement range	-100A~+100A
Communication interfaces	CAN
Available SOC range	3%~100%
Charge/Discharge efficiency (%)	>95
Operating temperature (°C)	-10 ~ 55
Storage temperature (°C)	-10 ~35
Humidity	5%~95%
Weight (kg)	6.5±1 kg
Dimensions (L*W*H) (mm)	440*420*122

5.3 Battery System Specifications

Specifications for Battery System							
The number of batteries	2*Mira-HV25	3*Mira-HV25	4*Mira-HV25	5* Mira-HV25	6*Mira-HV25	7* Mira-HV25	8* Mira-HV25
Normal voltage(V)	102.4	153.6	204.8	256	307.2	358.4	409.6
Normal capacity (Ah)	48	48	48	48	48	48	48
Voltage range(V)	92.8-117.6	139.2-176.6	185.6-235.5	232.0-294.4	278.4-353.2	324.8-412.1	371.2-471.0
Recommended charging current(A)	24						
Max. charge/discharge current (A)	48						
CC-CV charging cut-off current(A)	3						
Peak charge current(A)(30s)	60						
Peak discharge current(A)	60						
Operating temperature (°C)	Charge: 0°C ~55°C Discharge: -10°C ~55°C						
Storage temperature (°C)	-10°C ~35°C						
Cycle life	≥4000 @25°C @ 80%SOH						
Ingress protection	IP21						
Protective class	I						
Communication interfaces	CAN						
Altitude [m]	<2000						
Pollution degree	PD2						
Weight (kg)	66.7±1kg (Net)	94.8±1kg (Net)	123.0±1kg (Net)	151.1±1kg (Net)	179.2±1kg (Net)	207.3±1kg (Net)	235.5±1kg (Net)
	73.5±1kg (Gross)	104.1±1 kg (Gross)	134.6±1 kg (Gross)	165.1±1kg (Gross)	195.7±1 kg (Gross)	226.2±1 kg (Gross)	256.7±1 kg (Gross)

6. Product Features

6.1 Battery System Features

The batteries have been fitted with multiple protection systems to ensure the safe operation of the system. Some of the protection system includes:

- Inverter interface protection: Over voltage, Over current, External Short Circuit, Reverse Polarity, Ground Fault, Over Temp, In rush current
- Battery Protection: Internal Short Circuit, Over voltage, over current, over temp, Under voltage

The battery system contains the following Interface to allow it to connect and operate efficiently.

Mira-HV25 Features:

- interface:

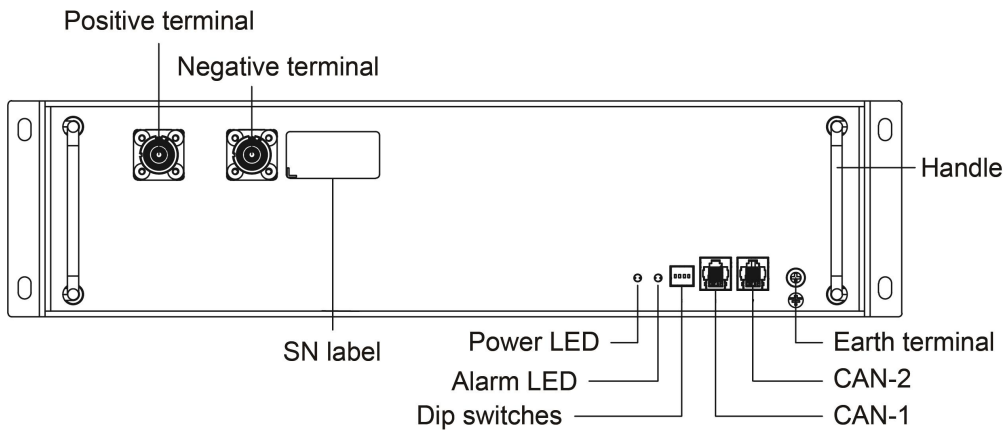

Power LED

This LED is used to indicate if the battery is operating effectively. A green light on this LED means the battery is ON and operating normally.

Alarm LED

This LED is used to indicate if the battery is operating failure. A red light on this LED means the battery is operating abnormally.

Communication Port A(CAN-1) and B(CAN-2)

Mira-HV25 has two CAN communication units in series operation, one for master control and one for slave control.

Network interface description: CAN-1 is connected to the upper battery module, CAN-2 is connected to the lower battery module.

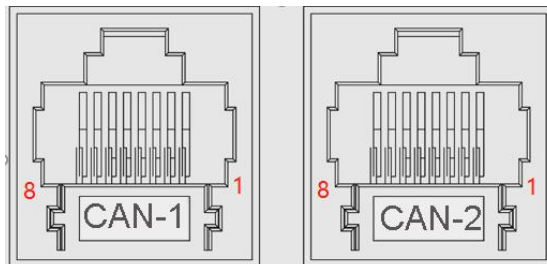

Pin configuration is as follows:

- CAN-1

Pin	Function Definitions	Function Declaration
1	IN_5V	Addressing input +5V
2	N-	Signal N-
3	P+	Signal P+
4	Wake_Up	Wake up the power supply+12V
5	CS_CANH	CAN-H
6	CS_CANL	CAN-L
7	BMU_COMM_GND	Isolated communication
8	GND	Slave power supply negative

- CAN-2

Pin	Function Definitions	Function Declaration
1	OUT_5V	Addressing output +5V
2	N-	Signal N-
3	P+	Signal P+
4	Wake_Up	Wake up the power supply+12V
5	CS_CANH	CAN-H
6	CS_CANL	CAN-L
7	BMU_COMM_GND	Isolated communication
8	GND	Slave power supply negative

Earth Terminal

This terminal is used to connect the battery to the earth for safety purposes.

Handle

The handle is used to push or pull the battery from its compartment. DO NOT LIFT THE BATTERY USING THIS HANDLE.

Power Terminal

A set of positive and negative terminals to connect the battery to the inverter. When you are unplugging the wires from the terminals, make sure you press the lock button and then pull it. When installing the plug, do not press the button and push the plug until you hear a click sound.

In addition to the above physical features, the battery has the following performance:

1. 80% State of Health
2. Cycle life >4000 cycles

Mira-BMS Features:

- interface

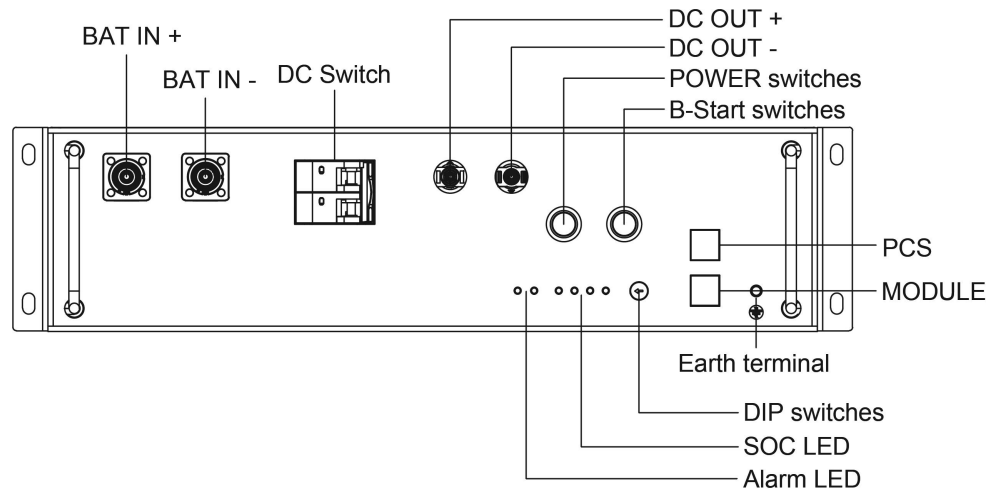

BAT IN +

Positive electrode of battery.

BAT IN -

Negative electrode of battery.

DC switch

Power switch, battery charge and discharge circuit switch.

DC OUT +

Connect bat + of inverter.

DC OUT -

Connect bat - of inverter.

POWER switches

System power on switch, press this switch, the system starts to work.

B-Start switches

Black start switches, if you want to start the battery system when there is no grid, press this switch first and then power on the system.

SOC LED

LED display battery system power and specific alarm information.

Alarm LED

If there is a fault in the system, the LED will display.

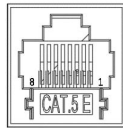
PCS & MODULE communication

PCS

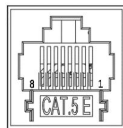

MODULE

- PCS

Pin	Function Definitions	Function Declaration
1	RS485-A	RS485-A
2	BMS-CANL	CAN-L
3	BMS-CANH	CAN-H
4	BMS-CANH	CAN-H
5	BMS-CANL	CAN-L
6	RS485-B	RS485-B
7	PCS-GND	Isolated communication
8	PCS-START	PCS wake-up signal

- MODULE

Pin	Function Definitions	Function Declaration
1	OUT_5V	Addressing output +5V
2	N-	Signal N-
3	P+	Signal P+
4	Wake_Up	Wake up the power supply+12V
5	CS_CANH	CAN-H
6	CS_CANL	CAN-L
7	BMU_COMM_GND	Isolated communication
8	GND	Slave power supply negative

Earth Terminal

This terminal is used to connect the battery to the earth for safety purposes.

7. Installation

7.1 Items in the package

Please check if following items are including with the package:

For Mira-HV25

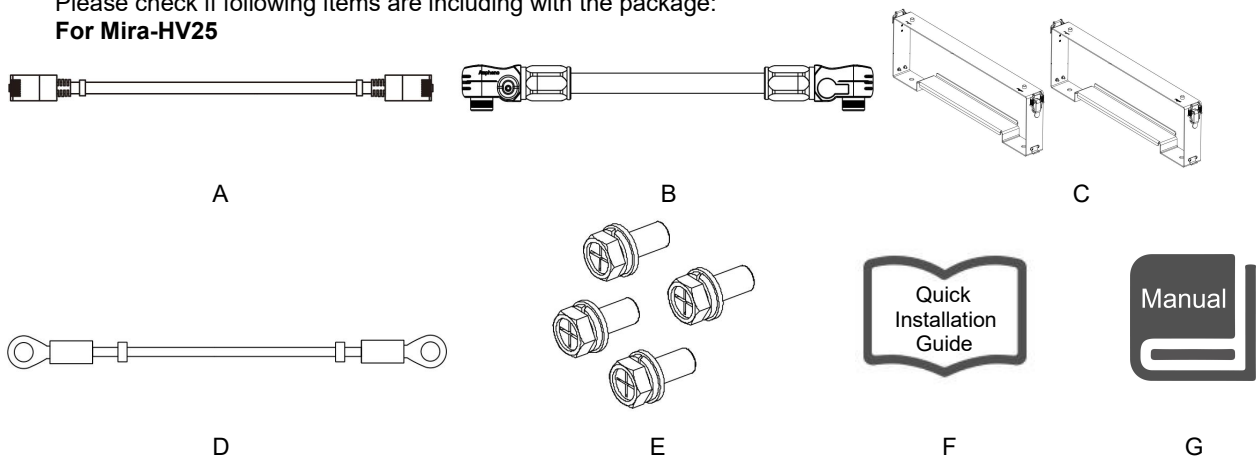

Number	Items	Number	Items
A	Communication cable (0.21m)	E	Mounting screw pack
B	Battery power cable (0.19m)	F	Installation guide
C	Fixing bracket	G	User Manual
D	Grounding cable (0.19m)		

Note: item C is provide separately, not including in battery package. Please contact your dealer if you do not have it.

For Mira-BMS

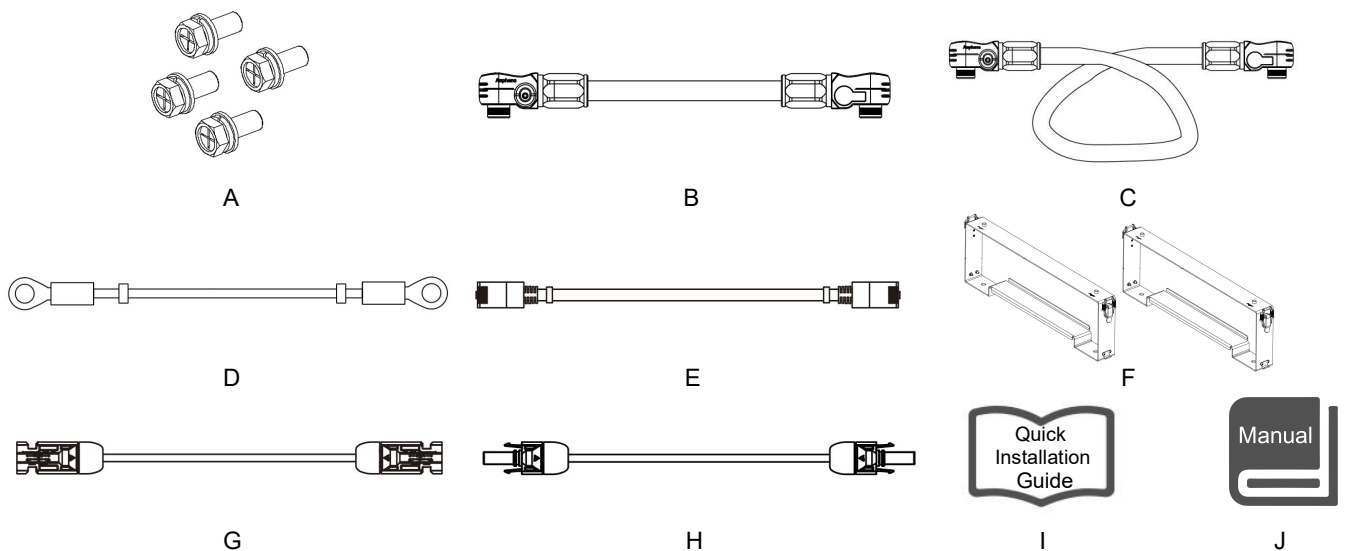

Number	Items	Number	Items
A	Mounting screw pack	F	Fixing bracket
B	Main negative battery connection cable (0.17m)	G	DC negative output cable (1.2m, 8AWG)
C	Main positive battery connection cable (1.3m)	H	DC positive output cable (1.2m, 8AWG)
D	Grounding cable (1m, 10AWG)	I	Installation guide
E	Communication cable (Mira-BMS-inverter) (1.2m)	J	User Manual

Note: item F is provide separately, not including in battery package. Please contact your dealer if you do not have it.

7.2 Clearance

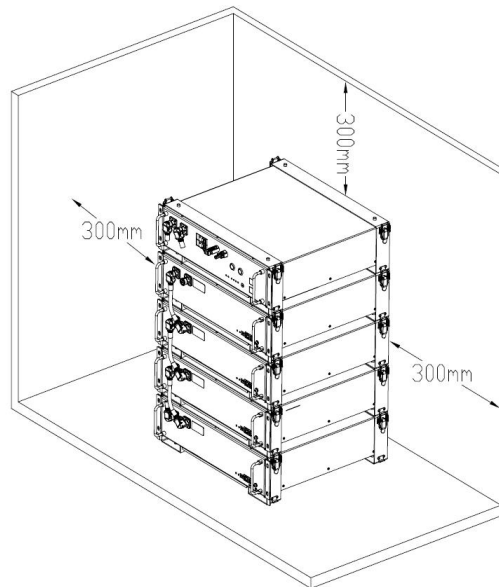

Make sure to leave a space of at least 300 mm. A clearance of at least 300 mm must be left around the battery pack for proper cooling.

Note: Make sure that the battery pack is always exposed to the ambient air. The battery pack is cooled by natural convection. If the battery pack is entirely or partially covered or shielded, it may cause the battery pack to stop operating.

7.3 Tools

The following tools will be required to install the Mira-BMS and the battery.



Screw Driver



Crimping Modular



Safety Shoes



Multimeter



Safety Gloves



Safety Goggles



Plier



Ribbon

7.4 Installation Steps

Step 1: Place the front bracket and back bracket as shown below.

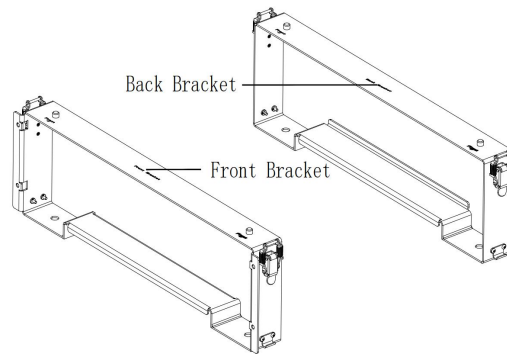

Step 2: Insert the battery module into the bracket from front horizontally, and tighten the four screws on the side.

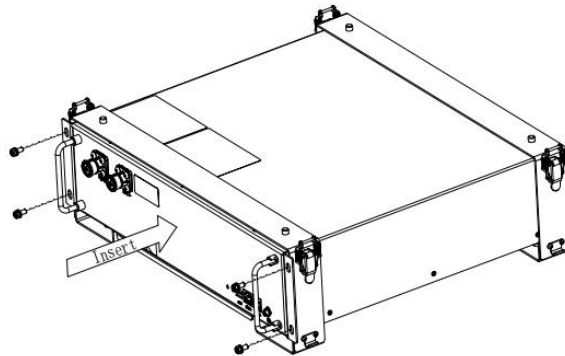

Step 3: Locate the brackets for the second battery on top of the first pair of the bracket and fasten the connecting button on the side.

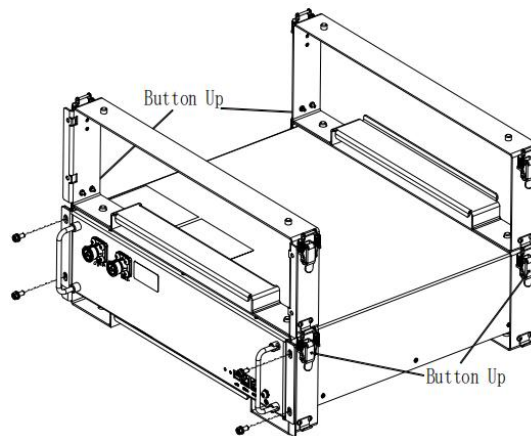

Step 4: Insert the battery module into the bracket from front horizontally, and tighten the four screws on the side.

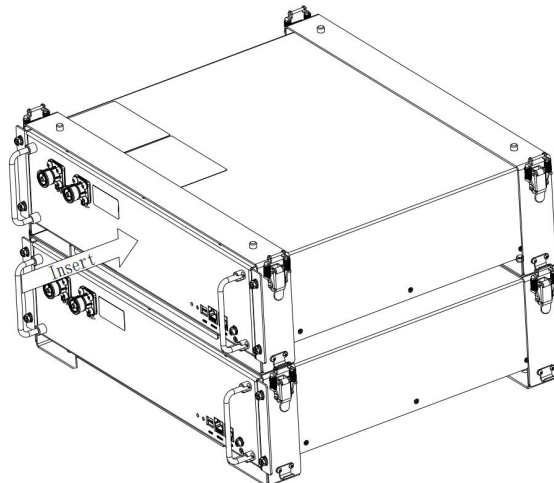

Step 5: Connect the inverter as shown in the figure below.

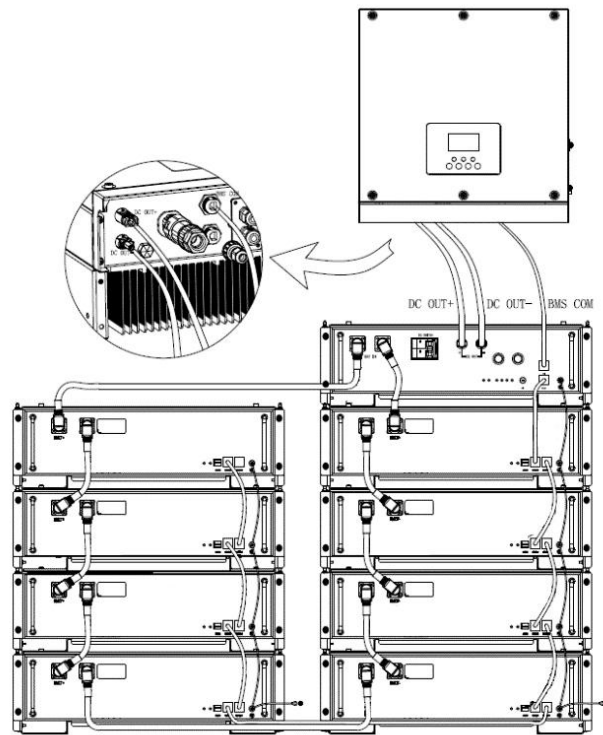

Note: If the Battery modules are more than 4 pieces, please separate into multiple stacks. Please make sure each stack only including max. 1 BMS and 4 battery modules.

Battery modules less than 4 pieces:

Battery modules more than 4 pieces:

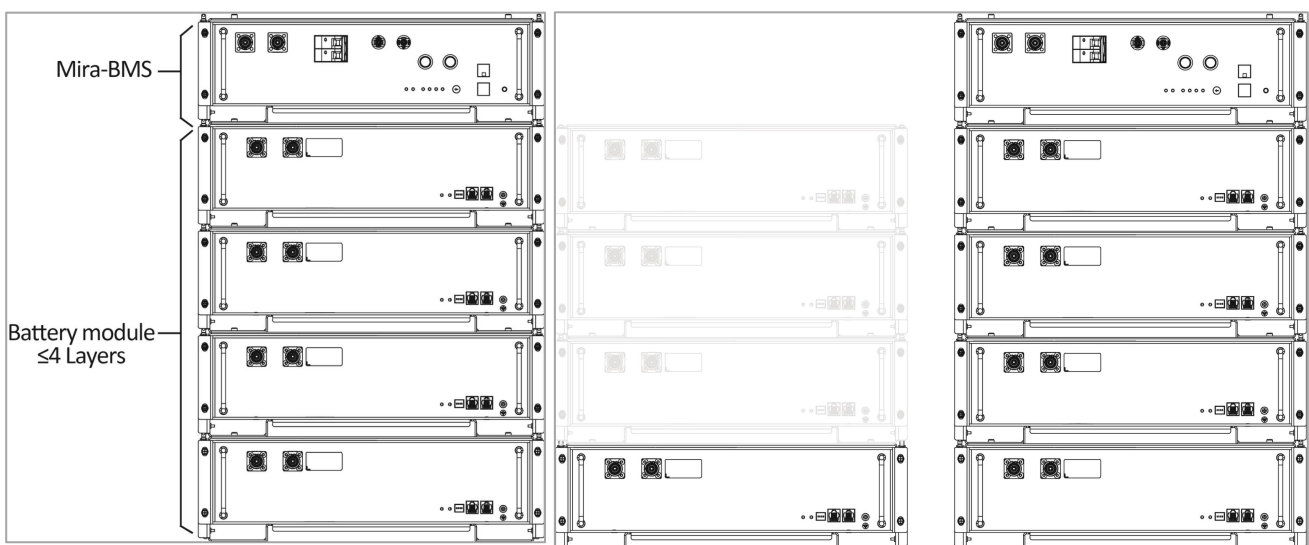

7.5 Wiring Steps

A. Battery power cable

Step 1: Connect the power cable starting from the first battery module in series with other battery modules (Orange opposite, black negative). A 'click' sound indicates the connections are secured. The positive and negative connection of the battery cable is shown in below.

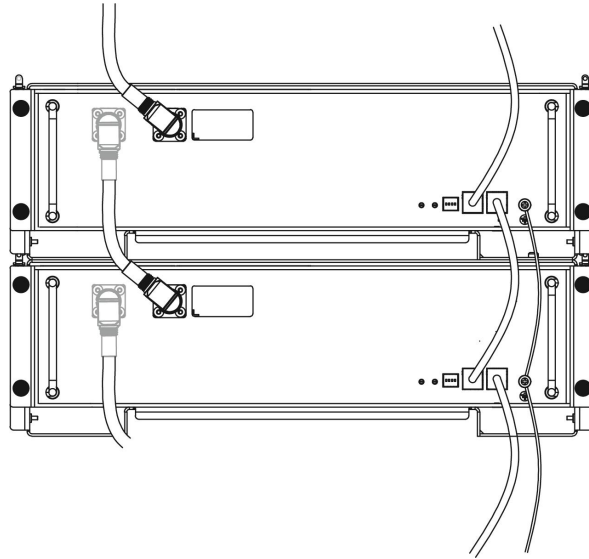

Step 2: Measure voltage value: After all battery modules are connected in series, use a multimeter to measure the DC voltage on DC terminal. The total voltage should be $N * 52 \pm 10V$ (N is the total number of battery module). Please refer to the picture below for voltage test.

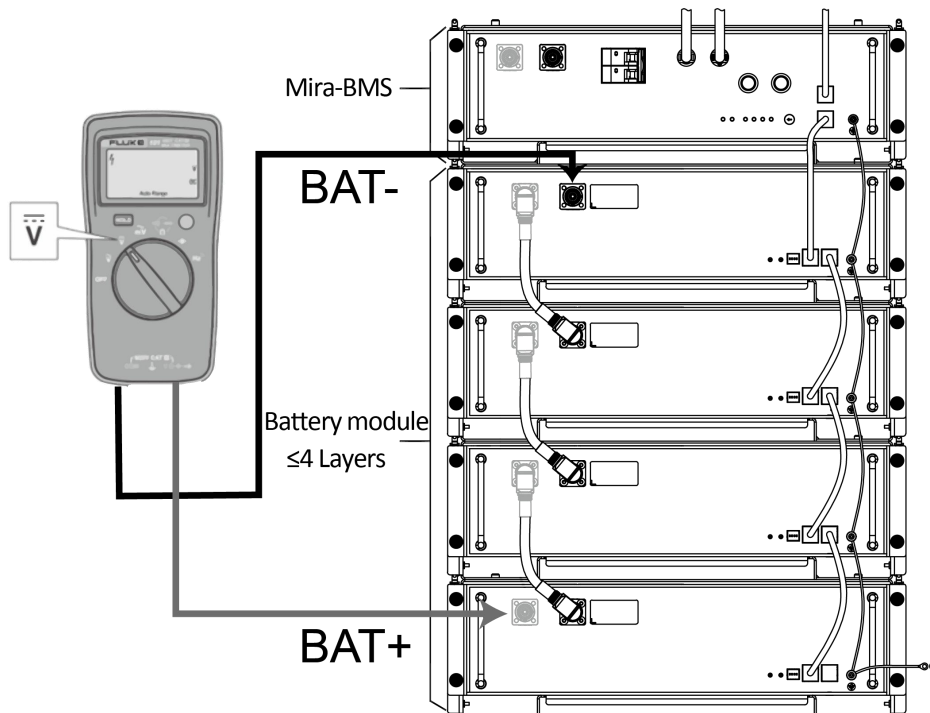

B. Communication cable connection:

Step 1: Take the main positive cable (two orange plugs), the main negative line (two black plugs) to connect the Mira-BMS.

Step 2: Then connect the MODULE on the Mira-BMS to the CAN-1 of the first battery module, connect the CAN-2 of the previous battery module to CAN-1 of the next battery module, leave the last module's CAN-2 vacant. Wiring shall be connected in the sequence as shown in below.

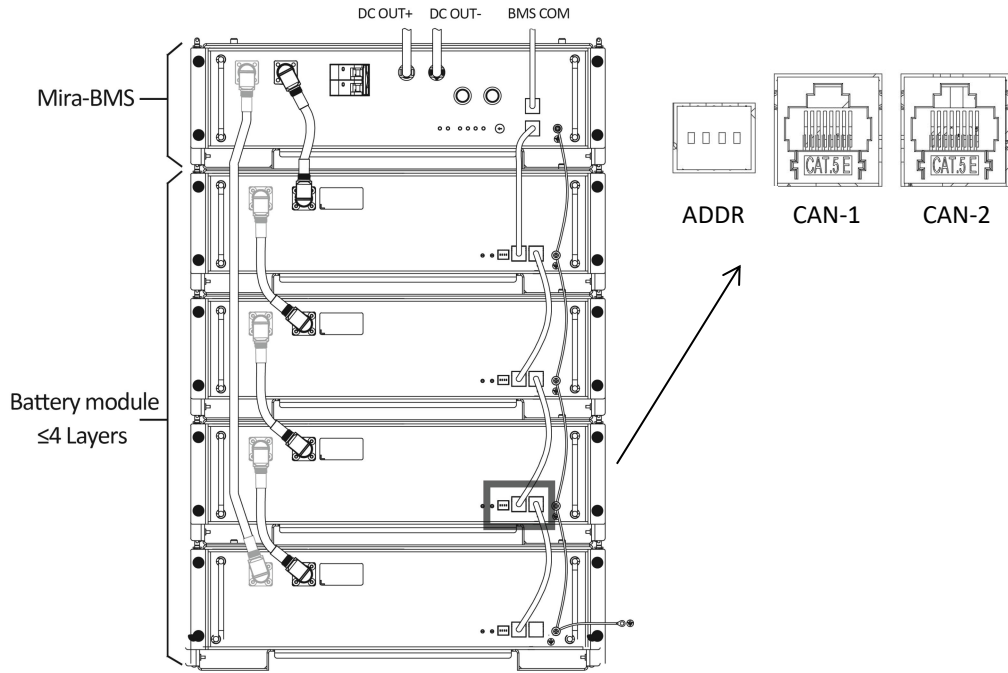

C. Grounding cable:

Connect the grounding cable to ensure that all batteries are grounded. Wiring shall be connected in the sequence as shown in below.

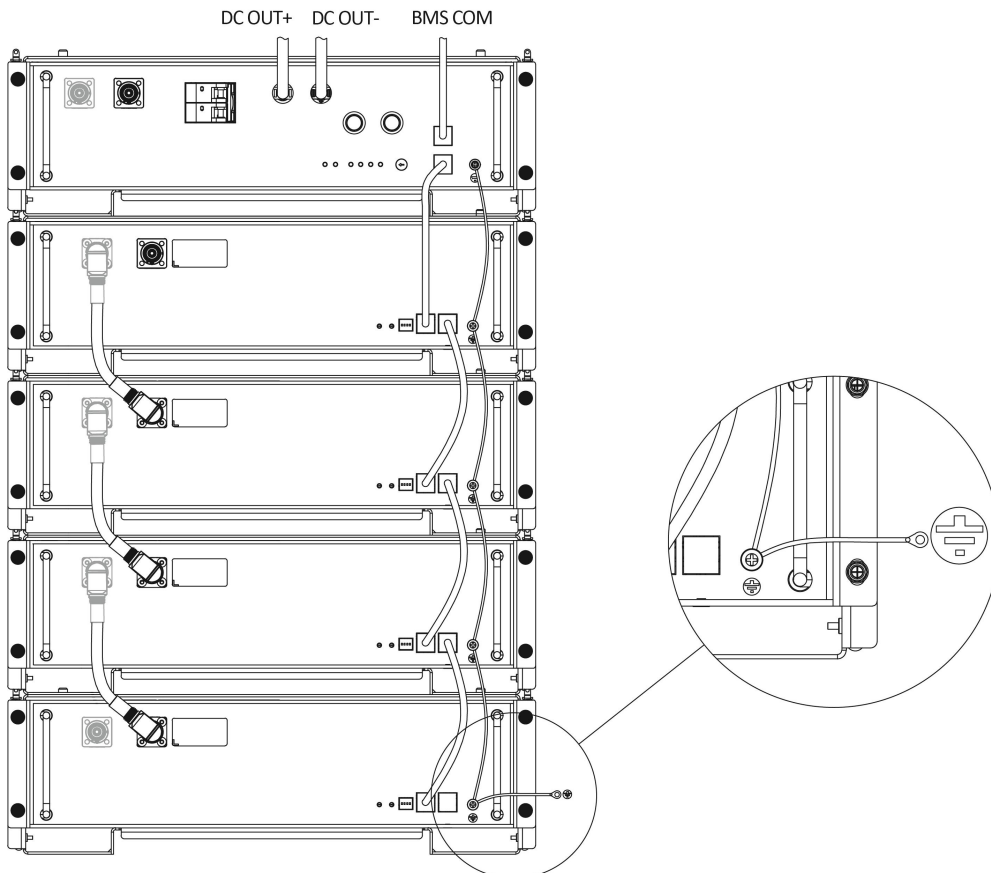

7.6 System Start up

- When the grid connected system is started, the inverter should be turned on first to avoid the current pulse of the inverter increasing to the battery pack.
- All installation and operation must comply with local electrical standards.
- Check all power cables and communication cables carefully.

1. Turn on the POWER switch

- After powering on, all the green lights flash once, and then the running water lights flash once. The light on the Mira-HV25 comes on after a delay, not at the same time as the light on the BMS.

2. Module address assignment

- If the system is powered on for the first time, Mira-BMS will automatically assign the module address of Mira-HV25 without manual configuration.

8. Commissioning

There are two LED indicators on the front of the battery packs to show its operating status.

For Mira-HV25

Green LED	Red LED	Batteries Status
On for 0.5s, Off for 0.5s	On for 0.5s, Off for 0.5s	Runing in boot
On for 0.1s, Off for 0.1s	On for 0.1s, Off for 0.1s	Upgrading
On for 1s, Off for 1s	Off	Normal Working
Off	On for 1s, Off for 1s	Alarm

For Mira-BMS

SOC	Status	Green LED	Red LED	LED4-1			
=100%	Standby	■	/	●	●	●	●
100% > SOC >= 75%		■	/	●	●	●	●
75% > SOC >= 50%		■	/	/	●	●	●
50% > SOC >= 25%		■	/	/	/	●	●
25% > SOC >= 0%		■	/	/	/	/	●
=100%	Discharge	●	/	●	●	●	●
100% > SOC >= 75%		●	/	●	●	●	●
75% > SOC >= 50%		●	/	/	●	●	●
50% > SOC >= 25%		●	/	/	/	●	●
25% > SOC >= 0%		●	/	/	/	/	●
=100%	Charge	●		■	■	■	■
100% > SOC >= 75%		●		■	■	■	■
75% > SOC >= 50%		●		/	■	■	■
50% > SOC >= 25%		●		/	/	■	■
25% > SOC >= 0%		●	/	/	/	/	■

Fault	Green LED	Red LED	LED4-1			
Under voltage fault	/	■	/	/	/	●
Over voltage fault	/	■	/	/	●	/
Over temperature fault	/	■	/	/	●	●
Under temperature fault	/	■	/	●	/	/
Discharge over current	/	■	/	●	/	●
Charge over current	/	■	/	●	●	/
Discharge over power	/	■	/	●	●	●
Charge over power	/	■	●	/	/	/
Pre-Charge failed	/	■	●	/	/	●
Short circuit Protection	/	■	●	/	●	/
AFE communication failed	/	■	●	/	●	●
Module Addressing failed	/	■	●	●	/	/
IVU Communication failed	/	■	●	●	/	●
BMU Communication failed	/	■	●	●	●	/
PCS Communication failed	/	■	●	●	●	●
HVB FUSE fault	/	●	/	/	/	●
Module FUSE fault	/	●	/	/	●	/
Power failed	/	●	/	/	●	●
Internal total voltage sampling failed	/	●	/	●	/	/
Temperature sampling failed	/	●	/	●	/	●
Relay adhesion	/	●	/	●	●	/
Relay Not Close	/	●	/	●	●	●
Relay drive failed	/	●	●	/	/	/
Single Cell "0V" fault	/	●	●	/	/	●
Temperature high permanent failed	/	●	●	/	●	/
The Single voltage high permanently failed	/	●	●	/	●	●
SOH low protection	/	●	●	●	/	/
AFE failed (UV/OV/UT/OT)	/	●	●	●	/	●
Shutdown failed	/	●	●	●	●	/
Other fault	/	●	●	●	●	●

Remark:

- : LED flash display (on: 0.5s, off: 0.5s)
- : LED on display

9. Exclusion

The warranty shall not cover the defects caused by normal wear and tear, inadequate maintenance, handling, storage faulty repair, modifications to the battery or pack by a third party other than Fox or Fox agent, failure to observe the product specification provided herein or improper use or installation, including but not limited to the following.

- Damage during transport or storage.
- Incorrect Installation of battery into pack or maintenance.
- Use of battery pack in inappropriate environment.
- Improper, inadequate, or incorrect charge, discharge or production circuit other than stipulated herein.
- Incorrect use or inappropriate use.
- Insufficient ventilation.
- Ignoring applicable safety warnings and instructions.
- Altering or attempted repairs by unauthorized personnel.
- In case of force majeure (ex: lightning, storm, flood, fire, earthquake, etc.).
- There are no warranties-implied or express-other than those stipulated herein. Fox shall not be liable for any consequential or indirect damages arising or in connection with the product specification, battery or pack.

10. Troubleshooting and Maintenance

10.1 Maintenance

- A. Regularly check whether the service environment of the battery meets the requirements, and the installation position should be far away from the heat source.
- B. In case of one of the following situations, it needs to be charged in time:
 - The battery is often under charged;
 - The battery has been out of use or stored for more than 3 months.
- C. Regularly check whether the battery and its supporting terminals, connecting cables and indicator lights are normal.

10.2 Troubleshooting

When the red / green LED on the panel is flashing or normally on, it does not mean that the Mira-HV25 is abnormal, it may be just an alarm or protection. Please check the 'LED status indicators' in chapter 7 for the detailed faulty definition before any trouble-shooting steps. In general, the alarm indication is normal without manual intervention. When the alarm triggering state is removed, Mira-HV25 will automatically return to normal use.

- Problem determination based on the following points

- 1) Whether the green light on the power switch is on;
- 2) Whether the buzzer in Mira-BMS on;
- 3) Whether the battery system can be communicated with inverter;
- 4) Whether the battery can be output voltage or not.

- Preliminary determination steps

Battery system cannot work, when DC switch on and POWER on, the LED doesn't light up or flash, please consider contact the local distributor.

- 1) The LED display of Mira-BMS and Mira-HV25 is normal, but it cannot charge and discharge. Observe the display screen of inverter and there is no SOC. Please check whether the CAN communication between Mira-BMS to inverter is well connected. If the connection is good, please replace a CAN communication cable. If the SOC is still not visible on the inverter display screen, please contact the local distributor.
- 2) After the battery system is powered on, if you can see the alarm information on the LED and inverter display screen at the same time, please contact the local distributor.

The copyright of this manual belongs to FOXESS CO., LTD. Any corporation or individual should not plagiarize, partially or fully copy (including software, etc.), and no reproduction or distribution of it in any form or by any means is permitted. All rights reserved.

FOXESS CO., LTD.

Add: No.939, Jinhai Third Road, New Airport Industry Area, Longwan District, Wenzhou, Zhejiang, China

Tel: 0510- 68092998

WWW.FOX-ESS.COM