

SWITCHOVER BOX FOR HUAWEI M1 SERIES INVERTERS



Entry

HWM1 switchgear enables permanent power supply for single-phase backup loads. The switchover box is only compatible with Huawei M1 series inverters. Using a switchgear with automatic switching, the back up circuits will be supplied when the grid is working properly, also at the time of grid breakdown. Energy to power emergency circuits can be provided from energy storage connected to the inverter, also from energy produced from photovoltaic modules. The system requires use LUNA2000 energy storage.

Technical parameters

SH-HWM1-SZR	
Compatibility	SUN2000 3-10 KTL M1
Grid type	TN-S / TNC-S
Emergency power source	Energy Storage / PV Generator
Grid parameters, V	230/400
Grid frequency, Hz	50
Max. output current of backup power supply, A	15
Max. value of inverter disconnection current ,A	16,9
Disconnection	3F + N
Switching time, s	≈ 2
Disconnection from the grid	K1/K2 25A
Protection backup loads	RCBO B16 30mA
Operating temperature, °C	-20÷40
IP rating	65
Dimensions H/W/D. , mm	384 / 319 / 144
Weight, kg	3,8
Cable glands	2 x M25 1 x M20 1 x M16
Inverter connection	Terminal block 6 mm ²
Grid connection	Terminal block 6 mm ²
Back up connection	Terminal block 6 mm ²
COM connection	Terminal block 6 mm ²

Connection diagram

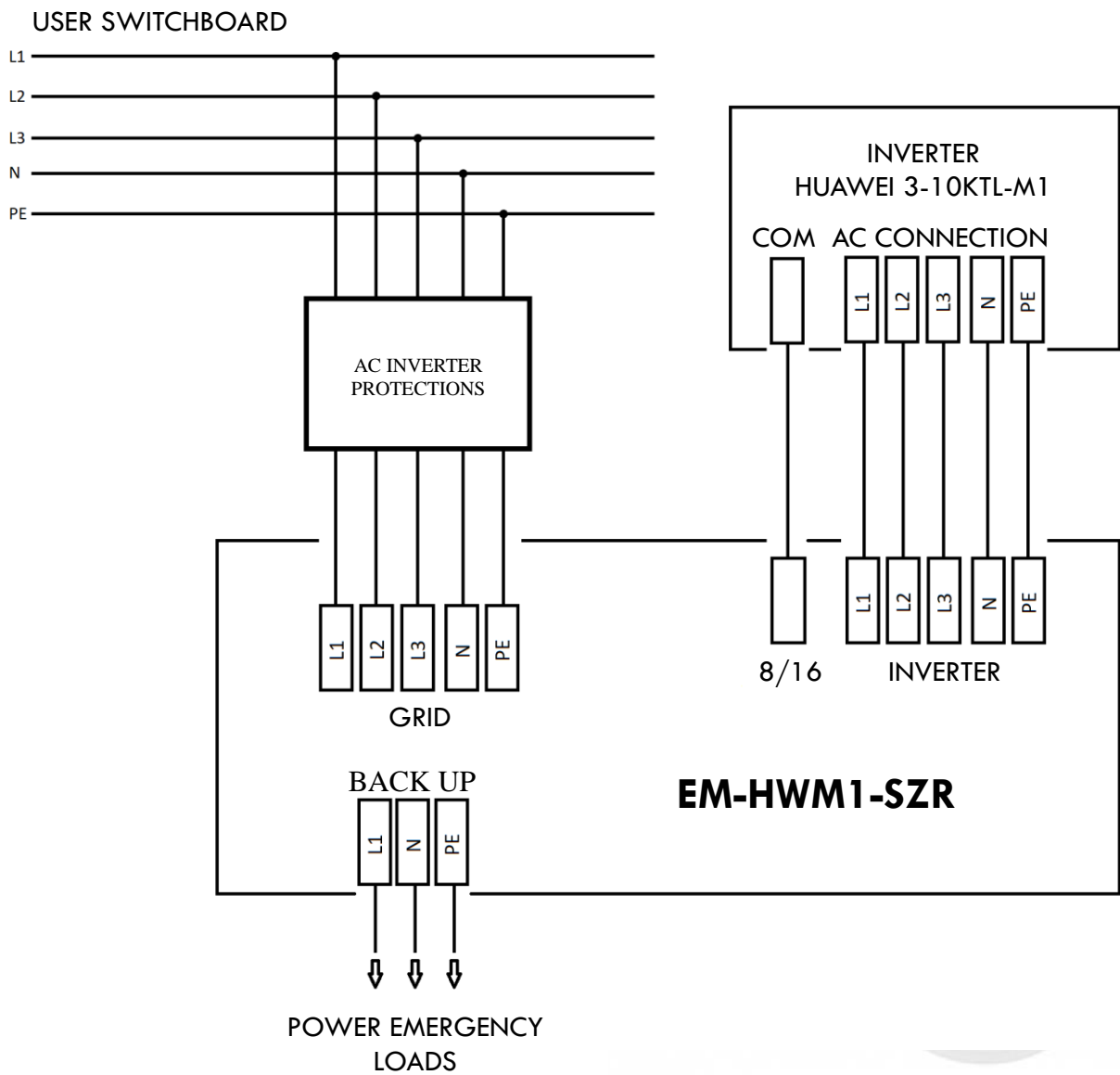

Emiter Sp. z o.o.

ul. Porcelanowa 27
40-241 Katowice

+48 32 730 34 00
emiter@emiter.net.pl

emiter.net.pl