

Datasheet GRENTON SMART PANEL WiFi WSP-204-W-0x

Replacing traditional wall switches, Grenton Smart Panel WiFi allows to control not only the light, but also any device in a smart home. The Panel provides information from sensors, system parameters or its functional data. The versatile and intuitive control interface makes it easy and quick to control an individual device or the whole home. There are 16 buttons at our disposal, spread over 4 pages. The pages can also control the thermostats defined in the system. More advanced users appreciate the "freedraw" mode that allows to generate any interface. It contains the Common Logic Unit (CLU) with WiFi wireless communication controller, executes the function of processing logic and storing the configuration.



1. Parameters - CLU WiFi

Properties:	
Uptime	Working time since last reset (in seconds)
ClientReportInterval	Reporting period for changes in properties
Date	Returns the current date
Time	Returns the current time (hh:mm:ss)
LocalTime	Returns the current time
TimeZone	Local time zone
UnixTime	Returns the current Unix time
FirmwareVersion	WiFi module firmware version
UseCloud	Specifies whether WiFi module connects to the Cloud
CloudConnection	Specifies whether WiFi module is connected to the Cloud
NTPTimeout	NTP Timeout
UseNTP	Specifies whether WiFi module uses NTP
PrimaryDNS	Preferred DNS server
SecondaryDNS	Alternate (secondary) DNS server
RSSI	Received signal strength indicator
Methods:	
SetDateTime	Sets date and time
StartConsole	Starts Lua console
StartConsoleOnReboot	Starts Lua console on next boot
FactoryReset	Factory reset of module
SetClientReportInterval	Sets the reporting period for changes in properties
SetPrimaryDNS	Sets the PrimaryDNS property
SetSecondaryDNS	Sets the SecondaryDNS property
Events:	
OnInit	Event occurs once during the device initialization
Virtual Objects:	
Timer	Timer operating in Interval or Countdown modes. Detailed interface description in the Grenton 2.0 System Manual - chapter XIII.5 Virtual Object - Timer

2. Parameters - PANEL_BUTTON

Properties:	
Value	Returns button input state as 0 or 1
Mode	Returns the selected mode of button action (0 - monostable, 1 - bistable, 2 - locked)
HoldDelay	Time in milliseconds after which, when pressing and holding a button, the OnHold event occurs
HoldInterval	Cyclical interval in milliseconds after which, when pressing and holding a button, the OnHold event occurs
Label	The text that describes the button
IconA	The file name of the icon assigned to the button in monostable and bistable mode in the OFF position. The name preceded by "~" displays the graphic in negative. IconA has priority on the Label property
IconB	The file name of the icon assigned to the button in bistable mode in the ON position. The name preceded by "~" displays the graphic in negative
Methods:	
SetMode	Sets mode of button action (0 - monostable, 1 - bistable, 2 - locked)
SetHoldDelay	Sets HoldDelay value
SetHoldInterval	Sets HoldInterval value
SetLabel	Sets Label value
SetIconA	Sets IconA value
SetIconB	Sets IconB value
ShowOK	Forces the green diode on the button to flash for 2 seconds (frequency 2Hz). The red diode on the button is off
ShowError	Forces the red diode on the button to flash for 2 seconds (frequency 2Hz). The green diode on the button is off
LedSwitchOn	Activates the green diode on the button
RedLedSwitchOn	Activates the red diode on the button
LedSwitchOff	Deactivates all the diodes on the button
Events:	
OnValueChanged	Event occurs when a change in the input state takes place (regardless of the value)
OnSwitchOn	Event occurs when the high state is set at input
OnSwitchOff	Event occurs when the low state is set at input
OnShortPress	Event occurs after pressing the button for 500 ms - 2000 ms
OnLongPress	Event occurs after pressing the button for 2000 ms - 5000 ms
OnHold	Event occurs for the first time after HoldDelay time passes and then cyclically every HoldInterval value
OnClick	Event occurs after pressing the button for less than 500 ms

3. Parameters - PANEL

Properties:	
GestureIconUp	The BMP file name of the icon for gesture Up (without extension)
GestureIconDown	The BMP file name of the icon for gesture Down (without extension)
GestureIconLeft	The BMP file name of the icon for gesture Left (without extension)
GestureIconRight	The BMP file name of the icon for gesture Right (without extension)
ProximitySens	Sensitivity of the proximity sensor (less value - more sensitivity)
ProximityTimeout	The time after which the display will be blanked
ProximityValue	Proximity sensor value (dimensionless value)
BuzzerValue	Sound indication control (0 - Off, 1 - On)
GestureMode	Selection of gestures orientation (0 - Off, 1 - Vertical, 2 - Horizontal, 3 - Vert+Horiz)
GestureSens	Selection of gestures sensitivity (1 - Low, 2 - Mid, 3 - High)
PageNr	Number of the current page displayed
PageDisplayMode	Notification before changing the page (0 - ShowImmediately, 1 - ShowIconOrName, 2 - ShowGesture)
ButtonsLEDMode	Buttons location using very low LED light (0 - LocationLedOff, 1 - LocationLedOn, 2 - LocationLedOnForActive)
PageControlMode	The source that switches the pages (0 - Command, 1 - Gesture/Command)
GestureDisplayMode	Displays information about the currently performed gesture (0 - Off, 1 - On)

Methods:	
SwitchOnDisplay	Wakes the display from sleep mode
ShowButtons	Changes display mode into "buttons". Clears the display and shows the icons (or text) for every button
ClearScreen	Clears the display in "freedraw" mode
PrintText	Displays the text in "freedraw" mode using parameters: (x, y, txt, font size)
PrintFloat	Displays the float number in "freedraw" mode using parameters: (x, y, number, precision, font size)
DrawLine	Draws the line in "freedraw" mode using the parameters: (x, y, xe, ye, color)
DrawBox	Draws the filled box in "freedraw" mode using the parameters: (x, y, w, h, color)
DrawPoint	Draws the point in "freedraw" mode using the parameters: (x, y, color)
DrawIcon	Draws the icon (bmp) in "freedraw" mode using the parameters: (x, y, Filename)
DisplayContent	Displays the memory graphic buffer content. Changes display mode to "freedraw"
SetGestureIconUp	Sets the icon for gesture Up
SetGestureIconDown	Sets the icon for gesture Down
SetGestureIconLeft	Sets the icon for gesture Left
SetGestureIconRight	Sets the icon for gesture Right
SetProximitySens	Sets the ProximitySens value
SetProximityTimeout	Sets the ProximityTimeout value (in seconds)
SetBuzzerValue	Sets the BuzzerValue (0 - Off, 1 - On)
SetGestureMode	Selection of gestures orientation (0 - Off, 1 - Vertical, 2 - Horizontal, 3 - Vert+Horiz)
SetGestureSens	Selection of gestures' sensitivity (1 - Low, 2 - Mid, 3 - High)
SetBeep	Generates sound according to frequency (Hz), duration (ms) and volume (freq, dur, vol, res)
SetPageNr	Sets the number of the page to be displayed
SetPageDisplayMode	Sets the mode of display notification before changing the page (0 - ShowImmediately, 1 - ShowIconOrName, 2 - ShowGesture)
SetButtonsLEDMode	Sets the buttons location mode using very low LED light (0 - LocationLedOff, 1 - LocationLedOn, 2 - LocationLedOnForActive)
SetPageControlMode	Sets the source that switches the pages (0 - Command, 1 - Gesture/Command)
SetGestureDisplayMode	Sets the mode of display information about the currently performed gesture (0 - Off, 1 - On)
SetNextPage	Forces the next page to be displayed
SetPrevPage	Forces the previous page to be displayed
Draw	Triggers the OnDraw event when OLED is active
Events:	
OnGestureUp	Event occurs after gesture Up
OnGestureDown	Event occurs after gesture Down
OnGestureLeft	Event occurs after gesture Left
OnGestureRight	Event occurs after gesture Right
OnProximityDetect	Event occurs after detection an object in front of the Smart Panel
OnPageChange	Event occurs after page change
OnDisplayOn	Event occurs after display on
OnDisplayOff	Event occurs after display off

4. Parameters - PANEL_PAGE

Properties:	
PageType	The type of page displayed on the Smart Panel (0 - Inactive, 1 - Buttons, 2 - Thermostats, 3 - FreeDraw)
PageName	Page Name/Icon Name of page displayed on the Smart Panel
Object_X_Id	ID of the thermostat object or the button number due to page type. X - object no. [1..4]
Object_X_Name	Name of the thermostat displayed on the Smart Panel page (no name - thermostat inactive). In the case of Buttons or FreeDraw page type, the Object_X_Name property should be empty. X - object no. [1..4]
DistributedLogicGroup_X	Inactive for WiFi devices. X - object no. [1..4]
Methods:	
SetPageType	Sets the type of page displayed on the Smart Panel
SetPageName	Sets the page name/icon name of page displayed on the Smart Panel
SetObject_X_Id	Sets the ID of the thermostat object or the button number due to page type. X - object no. [1..4]
SetObject_X_Name	Sets the Name of the thermostat displayed on the Smart Panel page (no name - thermostat inactive). In the case of Buttons or FreeDraw page type, the Object_X_Name parameter should be empty. X - object no. [1..4]
Events:	
OnPageOpen	Event occurs after new page is shown
OnPageClose	Event occurs after actual page is closed
OnDraw	Event occurs after FreeDraw page wants to be redrawn

5. Parameters - PANELSENSTEMP (temperature sensor)

Properties:	
Threshold	Hysteresis (accuracy 0.1°C) specifying the sensitivity when the following events are generated: OnValueChanged, OnValueLower, OnValueRise
Sensitivity	Period (in ms), for which the sampled values are averaged
Value	Temperature sensor value from 0.0 to 45.0°C
Calibration	Temperature calibration factor within -10°C to +10°C
MinValue	Minimum value of the Value property after exceeding which the OnOutOfRange event is generated
MaxValue	Maximum value of the Value property after exceeding which the OnOutOfRange event is generated
Events:	
OnValueChanged	Event resulting from changing input state
OnValueRise	Event resulting from exceeding the upper threshold of hysteresis
OnValueLower	Event resulting from exceeding the lower threshold of hysteresis
OnOutOfRange	Event resulting from exceeding the range (MinValue..MaxValue)

6. Parameters - PANELSENSLIGHT (light sensor)

Properties:	
Threshold	Hysteresis (accuracy 0.1%) specifying the sensitivity when the following events are generated: OnValueChanged, OnValueLower, OnValueRise
Sensitivity	Period (in ms), for which the sampled values are averaged
Value	Light sensor value from 0 to 100%
MinValue	Minimum value of the Value property after exceeding which the OnOutOfRange event is generated
MaxValue	Maximum value of the Value property after exceeding which the OnOutOfRange event is generated
Events:	
OnValueChanged	Event resulting from changing input state
OnValueRise	Event resulting from exceeding the upper threshold of hysteresis
OnValueLower	Event resulting from exceeding the lower threshold of hysteresis
OnOutOfRange	Event resulting from exceeding the range (MinValue..MaxValue)

7. Technical Data

Device power supply	230 V _{AC}
Average power consumption	<1.0 W
Maximal wire cross section	2.5 mm ²
WiFi frequency band	2.4 GHz
Weight	120 g
Dimensions (H/W/D)	surface part: 80/80/10 mm, concealed part: Ø 50 mm / h 22 mm
Operating temperature range	0 to +45°C

8. Wiring diagram

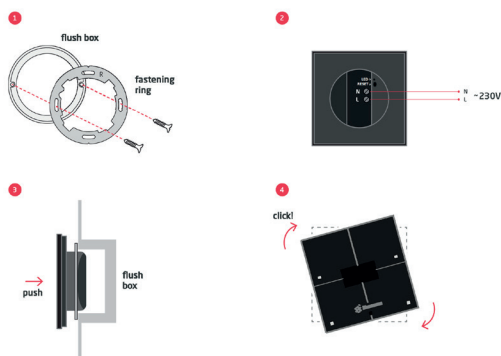

9. Wireless communication configuration

The brand new device on power up starts with the AP (access point) SSID: CLU47xxxxxx [reset] with the factory password (PIN) "00000000". After connection setup with the AP please connect to the device http server using web browser and <http://192.168.4.1> link. Next please set up a PIN and a WiFi network parameters, the WiFi network the device is meant to be connected to. The PIN is the new AP password and the

"Secret Key" used by the Object Manager tool during the discovery process as well. In case of connection failure with the previously configured WiFi network, the Smart Panel WiFi starts with the AP SSID: CLU47xxxxxx after 2 minutes of unsuccessful retries. After 10 minutes from the power on the AP is deactivated and the Smart Panel WiFi only keeps trying to connect to the configured WiFi network.

WiFi Setup

PIN:

SSID:

Password:

10. Device configuration in the Grenton System

After connecting the device to the WiFi network, please process configuration using the Object Manager tool. Select the CLU Discovery action in the upper left corner. Then set the "Beginning of IP address" not less than x.x.x.5. After discovering the device,

the Object Manager asks for a "Secret Key", it is the PIN mentioned earlier. Further configuration is the same as in the case of the CLU Z-Wave with devices connected via the TF-Bus.

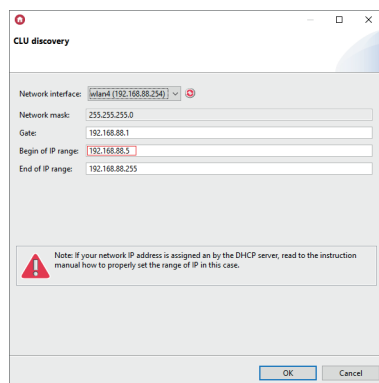

11. Restoring Factory Settings

Restoring Factory Settings initiates the RESET button hold over 5 seconds. Reset to the factory is indicated by the LED with stops blinking and turns on steady light.

12. Warnings and cautionary statements



ATTENTION !

- Before proceeding with the assembly, read the installation schematics and full instructions available at www.grenton.com. Failure to follow the guidelines contained in the instructions and other requirements of due care valid as a result of the nature of the equipment (device) may be dangerous to life / health, damage the device or installation to which it is connected, damage other property or violate other applicable

regulations. The manufacturer of the device, Grenton Sp. z o.o. does not bear any responsibility for the damage (property and non-property related) resulting from the assembly and / or use of the equipment not in accordance with the instructions and / or due diligence in handling the equipment (device).

- Device power supply, permissible load or other characteristic parameters have to be in accordance with the device specification, described in particular in the "Technical data" section.
- The product is not intended for children and animals.
- If you have technical questions or comments about the device operation, contact Grenton Technical Support.
- Answers to frequently asked questions can be found at www.support.grenton.pl



DANGER !

- Danger to life caused by electric current!
- The components of the installation (individual devices) are designed to work in a home electrical installation or directly in its

vicinity. Incorrect connection or use may cause a fire or electric shock.

- All work related to the installation of the device, in particular works involving interference in the electrical installation, may be performed only by a person with appropriate qualifications or licences.
- When installing the device, make sure that the power supply voltage is disconnected from the circuit in which the device is connected or near which the assembly takes place.

13. CE marking

The manufacturer declares that the device is in full compliance with the requirements of EU legislation that includes the directives of a new approach appropriate for this equipment. In particular, Grenton Sp. z o.o. declares that the device fulfills the requirements on safety, specified by law, and that it conforms to the na-

tional regulations that implement the appropriate directives: The Radio Equipment Directive (RED - 2014/53/UE), the Low Voltage Directive (LVD 2014/35/UE) and the Directive on the limitation of the use of specific substances in electrical and electronic equipment (RoHS II - 2011/65/UE).



14. Warranty

Warranty available at: www.grenton.com/warranty

15. Manufacturer contact details

Grenton Sp. z o.o.
ul. Na Wierzchowinach 3
30-222 Kraków, Polska (PL)
www.grenton.com