

Datasheet LED RGBW RGB-201-T-01

Grenton LED RGBW lighting control module enables smooth and full control of decorative lighting using LED RGBW technology. It also allows you to connect up to two digital inputs and two 1-wire sensors.



1. Parameters - LEDRGBW

Characteristics:	
Value	Brightness value as per the HSV model (range: 0.00-1.00)
Hue	Colour hue value as per the HSV model (0-360)
Saturation	Colour saturation value as per the HSV model (0.00-1.00)
RedValue	R component value (0-255) - Red
GreenValue	G component value (0-255) - Green
BlueValue	B component value (0-255) - Blue
WhiteValue	W component value (0-255) - White
RGB	Colour value as per the RGB model #RRGGBB (specified in HEX)
RampTime	Time value of increment of colour and brightness (in ms)
MaxValue	Maximum value which Value can adopt. Attempting to set a higher value will generate an error
MinValue	Minimum value which Value can adopt. Attempting to set a lower value will generate an error
RedCorrection	White correction - channel R (0-100), default 100%
GreenCorrection	White correction - G channel (0-100), default 100%
BlueCorrection	White correction - B channel (0-100), default 100%
StatisticState	Load measurement type: Off - turned off, Continuous - load measurement for the whole device's period operation
Load	The measured value multiplier. For StatisticState: Continuous - load measurement value in the unit of time
RedChannelDistributedLogicGroup	Distributed Logic group - red channel broadcast group for distributed logic
GreenChannelDistributedLogicGroup	Distributed Logic group - green channel broadcast group for distributed logic
BlueChannelDistributedLogicGroup	Distributed Logic group - blue channel broadcast group for distributed logic
WhiteChannelDistributedLogicGroup	Distributed Logic group - white channel broadcast group for distributed logic
Methods:	
SetValue	Sets output value (0.00-1.00)
SetHue	Sets hue value (0-360)
SetSaturation	Sets saturation value (0.00-1.00)
SetRedValue	Sets R component value (0-255)
SetGreenValue	Sets G component value (0-255)
SetBlueValue	Sets B component value (0-255)
SetWhiteValue	Sets W channel value (0-255)
SetRGBvalue	Sets RGB value using the #RRGGBB string
HoldValue	Executes illumination/dimming function
HoldHue	Executes smooth hue transition
SwitchOn	Sets output value to MaxValue
SwitchOff	Turns off all of the channels
Switch	Changes the output value from 0 to 1 or from 1 to 0. The first parameter is the time of change: 0 - switches output to continuous mode, number - switches output for a time specified by a parameter (in milliseconds) The second parameter is the ramp (time of value increments) which is optional. If this parameter is not specified, the default ramp is used.
SetRampTime	Sets value of increment of colour and input (in ms)
SetMaxValue	Sets maximum value for Value
SetMinValue	Sets minimum value for Value
HoldRedValue	Executes illumination/dimming function for R channel
HoldGreenValue	Executes illumination/dimming function for G channel
HoldBlueValue	Executes illumination/dimming function for B channel
HoldWhiteValue	Executes illumination/dimming function for W channel
Events:	
OnValueChanged	Event occurring when changing the output state
OnSwitchOn	Event occurring when the output state is changed from 0 to greater than 0
OnSwitchOff	Event occurring when 0 is set at the output
OnValueRise	Event occurring when the set value is higher than the current value
OnValueLower	Event occurring when the set value is lower than the current value
OnOutOfRange	Event occurring when set a value which is higher than the maximum value or lower than the minimum value

2. Parameters - DIN

Characteristics:	
Inertion	Inertion
HoldDelay	Time in milliseconds after which, when pressing and holding a button, the OnHold event occurs
HoldInterval	Cyclical interval in milliseconds after which, when pressing and holding a button, the OnHold event occurs
Value	Returns input state as 0 or 1
DistributedLogicGroup	Distributed Logic group - broadcast group for distributed logic
StatisticState	Load measurement type: Off - turned off, Continuous - load measurement for the whole device's period operation Pulse - load measurement counted at the moment of a high state appearing on the input
Load	The measured value multiplier. For StatisticState: Continuous - load measurement value in the unit of time Pulse - load measurement value for the single impulse (e.g. 1kw)
Methods:	
SetInertion	Minimum interval in milliseconds which has to pass between presses of a button so that it is interpreted as a new pressing activity
SetHoldDelay	Sets HoldDelay value
SetHoldInterval	Sets HoldInterval value
Events:	
OnValueChanged	Occurs when a change in the input state takes place (regardless of the value)
OnSwitchOn	Occurs when the high state is set at input
OnSwitchOff	Occurs when the low state is set at input
OnShortPress	Occurs after pressing the button for 500 - 2000ms
OnLongPress	Occurs after pressing the button for at least 2000ms
OnHold	Occurs for the first time after HoldDelay time and then cyclically every HoldInterval value
OnClick	Occurs after pressing the button for less than 500 ms

3. Parameters - PowerSupplyVoltage

Characteristics:	
Value	Current output value taking into account the scalar
Value %	Current percentage input value of the maximum value (MaxValue characteristic)
Sensitivity	Minimum change of input state when the OnValueChanged, OnValueLower or OnValueRise event is generated
MinValue	Minimum value of the Value characteristic after exceeding which the OnOutOfRange event is generated
MaxValue	Maximum value of the Value characteristic after exceeding which the OnOutOfRange event is generated
Methods:	
SetSensitivity	Sets input sensitivity value
SetMinValue	Sets MinValue
SetMaxValue	Sets MaxValue
Events:	
OnValueChanged	Event resulting from changing input state
OnValueLower	Event occurs when a value lower than the value from the last reading appears at input
OnValueRise	Event occurs when a value higher than the value from the last reading appears at input
OnOutOfRange	Event resulting from exceeding the permissible range (MinValue : MaxValue)
OnInRange	Event occurs when value returns to MinValue/MaxValue range

4. Technical data

Device power supply	24 V _{dc}
Maximum power consumption	0.48 W
Maximum device current	20 mA (for 24 V _{dc})
LED power supply (Vcc)	up to 24 V _{dc}
Maximum load current RGBW	12 A (total for all channels)
Maximum channel load current	4 A
Maximum wire cross section	1.5 mm ²
PWM output frequency	250 Hz
Weight	30 g
Fixing	flush mounted
Dimensions (H/W/D)	19/45/36 mm
Operating temperature range	0 to +45 °C

5. Wiring diagram

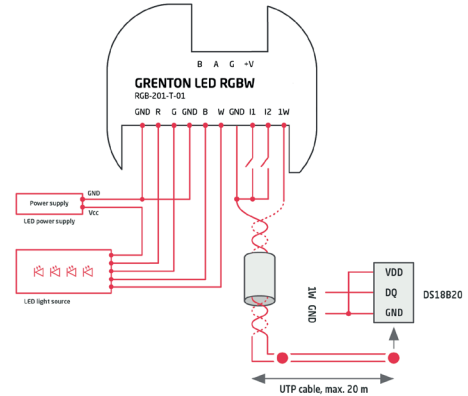

+V	Device power supply
G	GND for +V
A	A signal input
B	B signal input
1W	1-wire input
I2	second digital input
I1	first digital input
GND	GND for 1-wire and digital inputs
W	"White" output
B	"Blue" output
G	"Green" output
R	"Red" output
GND	GND

6. Warnings and cautionary statements



ATTENTION !

- Before proceeding with the assembly, read the installation schematics and full instructions available at www.grenton.com. Failure to follow the guidelines contained in the instructions and other requirements of due care valid as a result of the nature of the equipment (device) may be dangerous to life / health, damage the device or installation to which it is connected, damage other property or violate other applicable regulations. The manufacturer of the device, Grenton Sp. z o.o. does not bear any responsibility for the damage (property and non-property related) resulting from the assembly and / or use of the equipment not in accordance with the instructions and / or due diligence in handling the equipment (device).
- Device power supply, permissible load or other characteristic parameters have to be in accordance with the device specification, described in particular in the "Technical data" section.
- The product is not intended for children and animals.
- If you have technical questions or comments about the device operation, contact Grenton Technical Support.
- Answers to frequently asked questions can be found at: www.support.grenton.pl



DANGER !

- Danger to life caused by electric current!
- The components of the installation (individual devices) are designed to work in a home electrical installation or directly in its vicinity. Incorrect connection or use may cause a fire or electric shock.

vicinity. Incorrect connection or use may cause a fire or electric shock.

- All work related to the installation of the device, in particular works involving interference in the electrical installation, may be performed only by a person with appropriate qualifications or licences.
- When installing the device, make sure that the power supply voltage is disconnected from the circuit in which the device is connected or near which the assembly takes place.

7. CE marking

The manufacturer declares that the device is in full compliance with the requirements of EU legislation that includes the directives of a new approach appropriate for this equipment. In particular, Grenton Sp. z o.o. declares that the device fulfills the requirements on safety, specified by law, and that it conforms to

the national regulations that implement the appropriate directives: The Directive on the electromagnetic compatibility (EMC - 2014/30/EU) and the Directive on the limitation of the use of specific substances in electrical and electronic equipment (RoHS II - 2011/65/EU).



8. Warranty

Warranty available at: www.grenton.com/warranty

9. Manufacturer contact details

Grenton Sp. z o.o.
ul. Na Wierzbachach 3
30-222 Kraków, Polska (PL)
www.grenton.com