

Grenton I/O MODULE 2/2 allows you to control up to two outputs (max.350VA), two digital inputs and two 1-Wire sensors.



1. Parameters - DOUT

Characteristics:	
Value	Returns 1 for output set at On and 0 for output set at Off state
VoltageType	0 - AC, 1 - DC, signal
VoltageValue	Voltage value
Power	Returns power in watts
Overload	Maximum value of Power characteristic after exceeding which the OnOverload event is generated
SafeModeGroup	Safe mode group - broadcast group in case of emergency
Methods:	
SetValue	Sets output state to 1 or 0
Switch	Changes the output value from 0 to 1 or from 1 to 0. The first parameter is the time of change: 0 - switches output to continuous mode, number - switches output for a time specified by a parameter (in milliseconds)
SwitchOn	Sets output value to 1
SwitchOff	Sets output value to 0
SetVoltageType	Sets voltage type
SetVoltageValue	Sets voltage value
SetOverload	Sets overload value
Events:	
OnValueChanged	Occurs when a change in the state takes place (regardless of the value)
OnSwitchOn	Occurs when On(1) is set at output
OnSwitchOff	Occurs when Off(0) is set at output
OnOverload	Occurs when power value is equal or higher than overload value

2. Parameters - DIN

Characteristics:	
Inertion	Inertion
HoldDelay	Time in milliseconds after which, when pressing and holding a button, the OnHold event occurs
HoldInterval	Cyclical interval in milliseconds after which, when pressing and holding a button, the OnHold event occurs
Value	Returns input state as 0 or 1
StatisticState	Load measurement type: Off - turned off. Continuous - load measurement for the whole device's period operation, Pulse - load measurement counted at the moment of a high state appearing on the input
Load	The measured value multiplier. For StatisticState: Continuous - load measurement value in the unit of time Pulse - load measurement value for the single impulse (e.g. 1kW)
SafeModeGroup	Safe mode group - broadcast group in case of emergency
Methods:	
SetInertion	Minimum interval in milliseconds which has to pass between presses of a button so that it is interpreted as a new pressing activity
SetHoldDelay	Sets HoldDelay value
SetHoldInterval	Sets HoldInterval value
Events:	
OnValueChanged	Occurs when a change in the input state takes place (regardless of the value)
OnSwitchOn	Occurs when the high state is set at input
OnSwitchOff	Occurs when the low state is set at input
OnShortPress	Occurs after pressing the button for 500 - 2000ms
OnLongPress	Occurs after pressing the button for at least 2000ms
OnHold	Occurs for the first time after HoldDelay time and then cyclically every HoldInterval value
OnClick	Occurs after pressing the button for less than 500 ms

3. Parameters - PowerSupplyVoltage

Characteristics:	
Value	Current output value taking into account the scalar
Value %	Current percentage input value of the maximum value (MaxValue characteristic)
Sensitivity	Minimum change of input state when the OnValueChanged, OnValueLower or OnValueRise event is generated
MinValue	Minimum value of the Value characteristic after exceeding which the OnOutOfRange event is generated
MaxValue	Maximum value of the Value characteristic after exceeding which the OnOutOfRange event is generated
Methods:	
SetSensitivity	Sets input sensitivity value
SetMinValue	Sets MinValue
SetMaxValue	Sets MaxValue
Events:	
OnValueChanged	Event resulting from changing input state
OnValueLower	Event occurs when a value lower than the value from the last reading appears at input
OnValueRise	Event occurs when a value higher than the value from the last reading appears at input
OnOutOfRange	Event resulting from exceeding the permissible range (MinValue : MaxValue)
OnInRange	Event occurs when value returns to MinValue/MaxValue range

4. Technical data

Device power supply	24 V _{dc}
Maximum power consumption	0.95 W
Maximum device current	30 mA (for 24 V _{dc})
Rated load voltage	230 V _{ac} or 24 V _{dc}
Rated channel load AC1	1.5 A / 230 V _{ac}
Maximal breaking capacity AC1	350 VA
Relay type	NO, Inrush
Maximum wire cross section for relay outputs	2,5 mm ²
Maximum wire cross section for digital inputs	1,5 mm ²
Weight	30 g
Fixing	flush mounted
Dimensions (H/W/D)	19/45/36 mm
Operating temperature range	0 to +45 °C

5. Wiring diagram

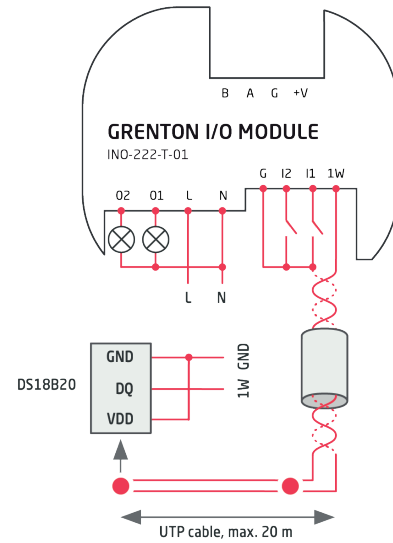

+V	Device power supply
G	GND
A	A signal input
B	B signal input
I1W	1-wire input
I1	first digital input
I2	second digital input
G	GND for 1-wire and digital inputs
N	'Neutral' signal
L	'Line' signal
O1	First relay output
O2	Second relay output

Relay outputs:
 • 'N' and 'L' signals are necessary for 230 V_{ac} loads for switch condition optimization.
 • 'L' signal supply O1 and O2.
 • For loads up to 24 V_{dc} switching signal has to be connected to 'L'. 'N' is not necessary in this case.

6. Warnings and cautionary statements



ATTENTION!

• Before proceeding with the assembly, read the installation schematics and full instructions available at www.grenton.com. Failure to follow the guidelines contained in the instructions and other requirements of due care valid as a result of the nature of the equipment (device) may be dangerous to life / health, damage the device or installation to which it is connected, damage other property or violate other applicable



DANGER!

• Danger to life caused by electric current!
 • The components of the installation (individual devices) are designed to work in a home electrical installation or directly in its

vicinity. Incorrect connection or use may cause a fire or electric shock.
 • All work related to the installation of the device, in particular works involving interference in the electrical installation, may be performed only by a person with appropriate qualifications or licenses.
 • When installing the device, make sure that the power supply voltage is disconnected from the circuit in which the device is connected or near which the assembly takes place.

7. CE marking

The manufacturer declares that the device is in full compliance with the requirements of EU legislation that includes the directives of a new approach appropriate for this equipment. In particular, Grenton Sp. z o.o. declares that the device fulfills the requirements on safety, specified by law, and that it conforms to

the national regulations that implement the appropriate directives: The Directive on the electromagnetic compatibility (EMC - 2014/30/UE) and the Directive on the limitation of the use of specific substances in electrical and electronic equipment (RoHS II - 2011/65/UE).



8. Warranty

Warranty available at: www.grenton.com/warranty

9. Manufacturer contact details

Grenton Sp. z o.o.
 ul. Na Wierzchowinach 3
 30-222 Kraków, Polska (PL)
www.grenton.com